

INSTRUCTION MANUAL

Type CFB Fixed Capacitor Banks

Low Voltage

Nema 1 (Indoor) and Outdoor enclosed versions

Table of Contents

- 1. Introduction and Safety Instructions**
- 2. Basic Power Factor Theory**
- 3. Determine Your Benefits from Improved Power Factor**
- 4. Basic Electrical Diagram**
- 5. Transportation, Handling and Storage**
- 6. Installation and Start-Up Procedures**
- 7. Electrical Connection & Wiring**
- 8. Specifications**
- 9. Technical Data and Dimensions**
- 10. Capacitor Cell Dimensions and Data**
- 11. Maintenance**
- 12. Troubleshooting Guide**

1.0 PRIOR TO INSTALLATION

This manual is intended to serve the user as a general guide for the installation and maintenance of Fixed Power Factor Capacitor Banks.

The instruction manual must be read carefully before unpacking, installation and maintenance.

Arteche Power Factor Capacitor Banks are designed and intended for compensation of reactive current and power demands associated with inductive loads (such as induction motors). The customer is responsible for determining the capacitor suitability for their specific application and for installing, connecting, using and maintaining the capacitor in an appropriate manner and within its specifications.

1.1 Catalog Numbering System

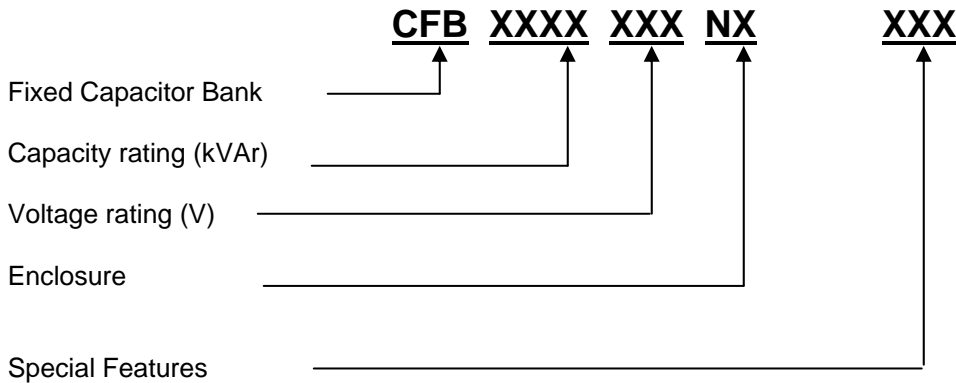

Enclosure designation (Add "suffix"):

Nema 1 (indoor)	"N1"
Outdoor	"N3R"
Oiltight/dusttight	"N12"

Special Features designation (Add "suffix"):

Fusing with blown fuse indicator	"FUS"
Circuit Breaker	"ITM"

Catalog No.Example:

A 250 kVAr, 480V, Nema 1, Non-Fused Power Factor Capacitor Bank is defined as: **CFB 0250 480 N1**

A 75 kVAr, 480V, Nema 1, Fused Power Factor Capacitor Bank is defined as: **CFB 0075 480 N1 FUS**

Read all safety instructions (next page) prior to beginning installation.

SAFETY INSTRUCTIONS



!! CAUTION – High Voltage !!



WARNING - THE EQUIPMENT COVERED BY THIS PUBLICATION MUST BE SELECTED FOR A SPECIFIC APPLICATION AND MUST BE INSTALLED, OPERATED AND MAINTAINED BY QUALIFIED PERSONNEL WHO ARE THOROUGHLY TRAINED AND WHO UNDERSTAND ANY HAZARDS WHICH MAY BE INVOLVED. THIS MANUAL HAS BEEN WRITTEN FOR SUCH QUALIFIED PERSONNEL EXCLUSIVELY AND IS NOT INTENDED TO BE A SUBSTITUTE FOR ADEQUATE TRAINING IN SAFETY PROCEDURES FOR THIS TYPE OF EQUIPMENT.

WARNING – Only qualified electricians should handle the installation of this capacitor bank, otherwise electric shock or fire may occur.

CAUTION – Improper handling may cause mis-operation and reduce the life of the capacitor bank.

CAUTION – This manual should be given to the user of this product and should be kept in a safe place until the capacitor bank is removed from service.

WARNING – Disconnect all electrical power from the circuit into which the capacitor bank is being installed. Extreme caution must be taken to prevent contact with high voltage during installation, operation and service of this equipment. Accidental contact with high voltage can result in personal injury or death.

WARNING – Capacitors must be fully dis-charged prior to performing any service, maintenance, or replacement of any part of the capacitor bank. Capacitors will store energy for a time period of up to five minutes. Using a DC voltmeter, confirm that the capacitor has entirely discharged as evidenced by zero voltage present between the capacitor terminals prior to performing installation, operation or service procedures. Accidental contact with energized parts may cause personal injury or death.

WARNING - There can be several energized parts inside the capacitor bank while power is applied. Disconnect all electrical power to the circuit before installing or servicing the capacitor bank. Accidental contact with energized parts may cause personal injury or death.

WARNING – Observe torque requirements for all electrical connections. When making connection using crimp terminals, be sure to use the crimping tool recommended by the terminal manufacturer. Wire and cable connections having improper torque may cause fire.

WARNING – The ground terminal should always be connected to the ground using a conductor which is the same diameter (gauge) as the phase conductor. Lack of ground connection or improper grounding may result in electric shock or fire.

WARNING - Install capacitor bank in accordance with all applicable local electrical standards (NEC NFPA 70, etc). Failure to properly install capacitor bank in accordance with local electrical safety standards may cause electric shock, fire or service disruption.

WARNING – Install capacitor bank in an enclosure that will prevent accidental contact with live parts and by using proper wire sizes as dictated by local electrical safety standards. Accidental contact with energized parts may cause personal injury or death.

CAUTION – Install capacitor bank in an enclosure that will prevent foreign matter such as paper, lint, wood chips, metallic chips from contact with live parts, otherwise fire, personal injury or equipment mis-operation may occur.

We strongly recommend that the installation, operation and maintenance of this equipment be handled by an electrician, engineer or technically qualified electrician with experience in electrical power equipment.

2.0 Basic Power Factor Theory:

Power Factor compares the active power (kilowatts or kW) with apparent power (KVA) that is demanded from the power source. It is also a comparison of the active current to the total current., as shown in the triangle below. It is also equal to the cosine of the angle of displacement between the voltage and current waveforms. The ratio of actual power to apparent power is usually expressed in percentage and is called power factor.

$$PF = \frac{kW}{kVA} = \cos \phi$$

Motors, transformers and other inductive equipment in a plant require two kinds of electric power. One type is working power, measured by the kilowatt (kW). This is what powers the equipment and performs useful work. Secondly, inductive equipment needs magnetizing power to produce the flux necessary for the operation of inductive devices. The unit of measure of magnetizing or reactive power is the kilovar (kVAR). The working power (kW) and reactive power (kVAR) together make up apparent power which is measured in kilovolt-amperes (kVA). By representing these components (kW and kVAR) of apparent power (kVA) as the sides of a right triangle, we can determine the apparent power from the right triangle rule. To reduce the kVA required for any given load, you must shorten the line that represents the kVAR. This is the function of power factor capacitors.

$$kVA^2 = kW^2 + kVAR^2$$

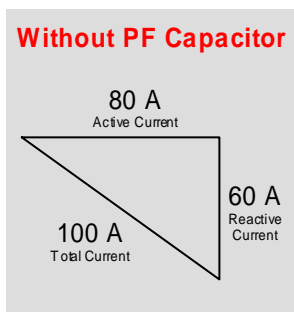

Most AC power systems require both kW and kVAR. Capacitors installed near the loads in a plant are the most economical and effective way of supplying these kilovars. If not supplied by local capacitors, then these kilovars will need to be provided by the electric utility. Low voltage capacitors are considered a low cost, high reliability and maintenance free means of providing the needed kilovars.

Capacitors can efficiently supply the reactive current to inductive loads, so those kilovars do not have to be sent all the way from the utility generator to the inductive loads. This relieves both your electrical system and utility network of the cost of carrying these extra kilovars. When the utility supplies these kilovars to you, they often charge you extra for this reactive power. Capacitors can reduce your utility bill by eliminating these extra charges. They will also help you to regain system capacity, improve voltage and reduce branch circuit I²R power losses.

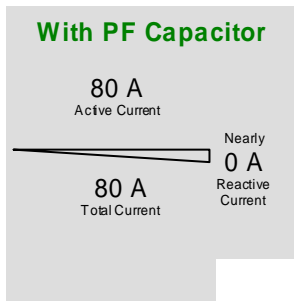

By supplying kVAR right at the load, the capacitor relieves the utility of the burden of carrying the extra kVAR. This makes the utility transmission/distribution system more efficient, reducing cost for the utility and their customers.

The addition of capacitors has improved power factor by subtracting from the inductive kVARs. This reactive current is now supplied by the capacitor rather than the utility.

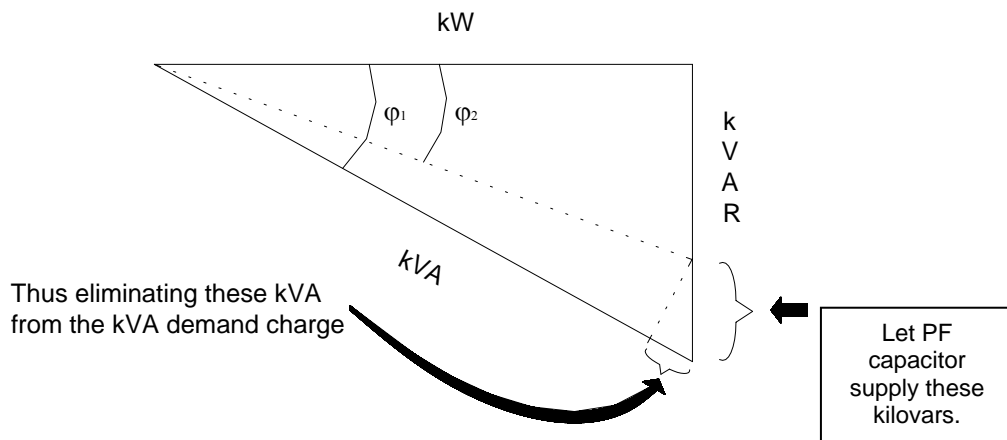

3.0 Determining your Benefits from improved Power Factor

There are several benefits that can be realized by improving power factor, including lower electric bills, reduced current in circuit conductors, reduced branch circuit power losses, reduced KVA requirement and reduced CO₂ emissions. Electrical benefits are realized on that portion of the electrical system which is upstream of the capacitor connection point.

- 1) **Electric Bill** – savings depend on your utility rate structure, power factor and demand. Arteche will calculate this for our customers when you provide a 12 month history of your usage and utility rate structure (most electric bills include this information).
- 2) **Reduced Current** - Power factor capacitors supply the reactive current needed by motors, so this reactive current does not need to be supplied by the power sources located upstream of the capacitor. Motor current remains the same, but current measured upstream of the capacitor is reduced.
- 3) **Reduced Branch Circuit Power Losses** - Branch circuit conductors in the circuits where capacitors are applied, will see lower current (upstream of the capacitor connection) and therefore I² R power losses in those branch circuits (and in upstream transformers) will be reduced.
- 4) **Reduced KVA** - Reduced circuit current results in a proportional reduction of KVA demanded from the power source. This means that some KVA capacity becomes available to supply additional loads from the existing power sources. If no additional loads are connected, then this reduces the KVA demanded from your utility.
- 5) **Reduced CO₂ Emissions** - When current and KVA demand are reduced, then less KVA is required from utility electricity generation, thus less carbon dioxide is produced.

Estimate your CO₂ emissions reduction (based on USA national average):

$$\text{kVA reduction} \times \text{number of operating hours} \times 1.34 = \text{lbs CO}_2 \text{ saved}$$

Example: Facility with 800kW and PF = 0.80 improves to PF = 0.95 (3000 hours per year).

Current situation: $800 \div 0.800 = 1000\text{KVA}$ [600kVAR]

Improved situation: $800 \div 0.950 = 842\text{KVA}$ [262.6 kVAR]; reduces kVA is $1000 - 842 = 158$ kVA.

CO₂ emissions reduction: 317.6 Tons [288 metric tons] per year

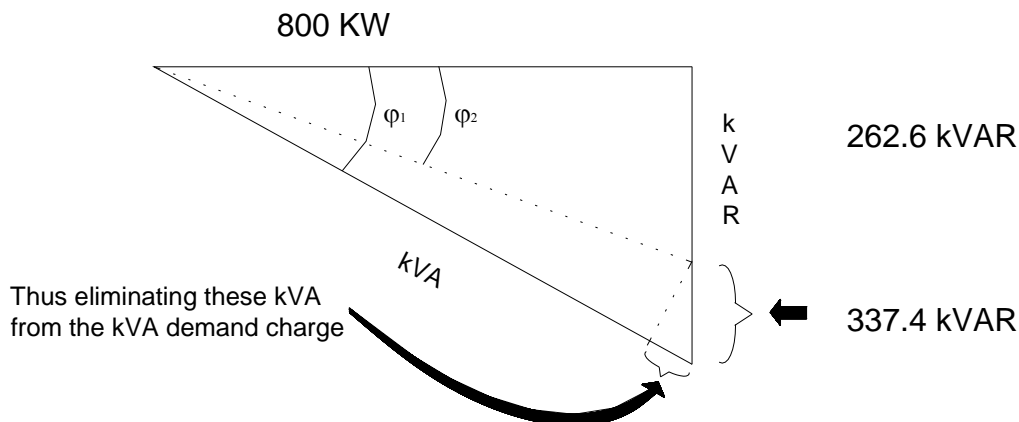

$$158 \times 3000 \times 1.34 = 635,160 \text{ lbs CO}_2 \text{ [317.6 Tons CO}_2\text{; 288 metric tons CO}_2\text{]}$$

4.0 Basic Electrical Diagram (shown with fuses and blown fuse indicators)

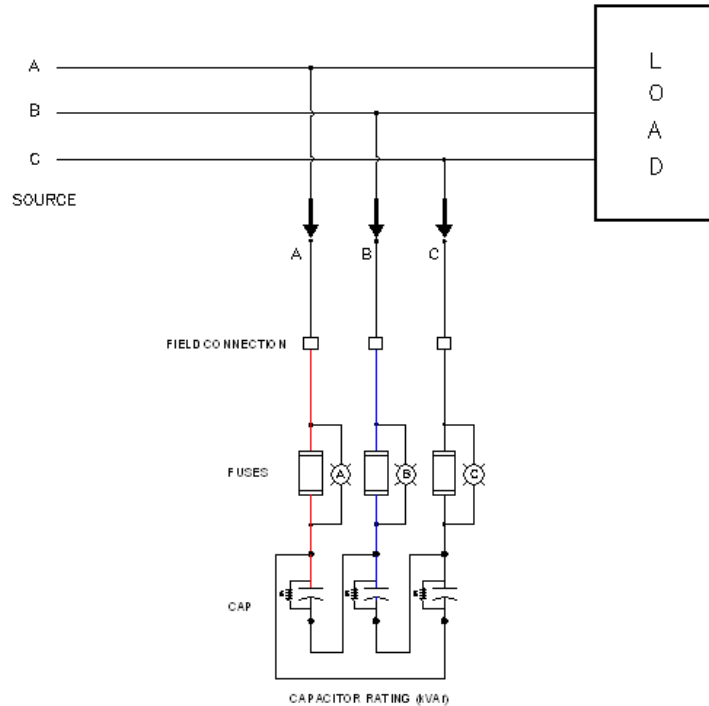

5.0 Transportation, Handling and Storage

Fixed capacitor systems are packed in corrugated cardboard boxes and as necessary will be over-packed and shipped in wooden crates to offer maximum protection during shipment. Transportation and handling of the capacitor system must always be done with the capacitor bank in a vertical position.

Upon arrival, the packing list and shipment should be carefully checked for completeness. The crating must be examined for transit damage. In the event of visible transit damage, a claim must be filed immediately with the carrier. In the event that the equipment is not installed immediately after arrival, it should be placed in intermediate storage without removing the packing. In this case, the crates are to be stored on a level area of sufficient strength to bear their weight and in a clean and non-corrosive atmosphere. If the intermediate storage is outdoors the period of storage must be limited to approximately 6 months, depending on the atmospheric conditions. This storage time will only affect the wooden packing and will not affect capacitor cells.

6.0 Installation



WARNING – Disconnect all electrical power from the circuit into which the capacitor bank is being installed. Extreme caution must be taken to prevent contact with high voltage during installation, operation and service of this equipment. Accidental contact with high voltage can result in personal injury or death.

6.1 Mechanical Installation

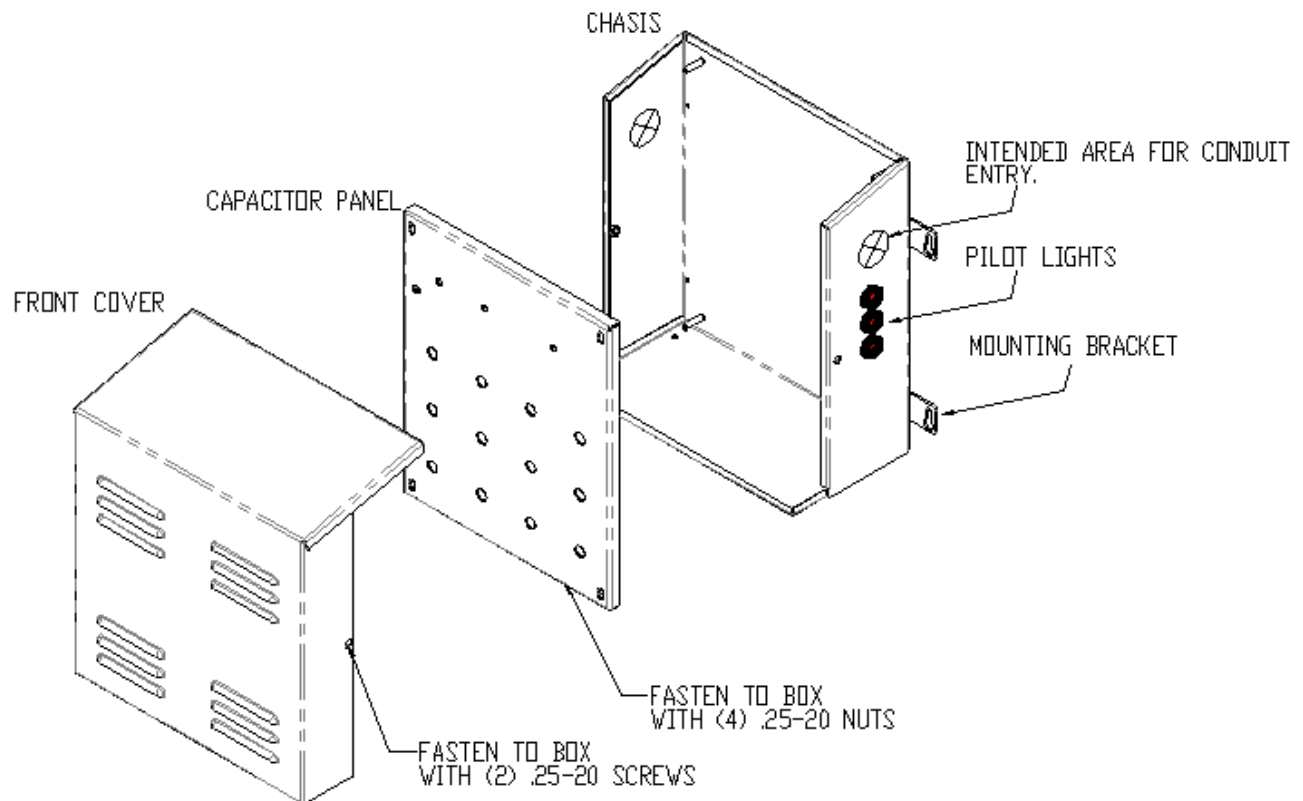

Picture is for reference only - actual appearance may vary

To open the capacitor bank enclosure, remove two screws located on each side (near top). Grasp the front cover and tilt it forward and downward to unlatch tabs at enclosure bottom.

- 6.1.1 Inspect the capacitor both internally and externally to make sure that no physical damage has occurred during shipment or handling.
- 6.1.2 Power factor capacitor banks must be installed only by trained and qualified personnel.
- 6.1.3 Capacitor banks should be located in a well ventilated area. The place selected for the installation must have a minimum of 2 inches space around all sides of the capacitor bank enclosure to assure good air circulation. Equipment rated for indoor use should be installed indoors in a dry environment. Mechanically secure the capacitor bank to either the wall or floor.

- 6.1.4 Connect the capacitor bank by securing power (feeder) conductors into the lugs and tighten per chart below. Connect ground conductor into grounding lug and secure by tightening per torque requirements chart in section 6.4).
- 6.1.6 Conduit sizes, tray sizes and cable ampacity must be according National Electrical Code or applicable electrical codes in your area.

After the capacitor bank has been mechanically installed, verify the torques of all the electrical connections, as per the bolt tightening torque chart in Section 6.3. Make sure the equipment is properly connected to ground using the grounding terminal provided.

6.2 Electrical Installation

WARNING – Disconnect all electrical power from the circuit into which the capacitor bank is being installed. Extreme caution must be taken to prevent contact with high voltage during installation, operation and service of this equipment. Accidental contact with high voltage can result in personal injury or death.



WARNING - Whenever using current transformers, never energize the circuit if the secondary leads of the current transformer are not connected to a suitable load or otherwise adequately shorted circuit !!

WARNING – Only qualified electricians should handle the installation of this capacitor bank, otherwise electric shock or fire may occur.

- 6.2.1 See Section 7.0 for alternative methods of connecting power factor capacitors in motor circuits.
- 6.2.2 In accordance with NEC 460, power factor capacitors must be provided with a disconnecting means and over current protection. When connecting the capacitor bank on the load side of a motor starter overload relay, it is not necessary to provide a disconnecting device or over current protection. Fuses should be rated at least 165% of rated capacitor current. A circuit breaker should be rated at least 135% of the rated capacitor current.
- 6.2.3 Proceed to connect the feeder cables to the main switch. This operation must be performed with the equipment completely de-energized.
- 6.2.4 Verify the torque of all terminals (Interrupting, fuses, contactors, etc.), as they may have loosened during transportation. See table in Section 6.3.

6.3 General Bolt Tightening Torque Requirements

Use these torque values unless directed otherwise elsewhere in this manual.

Bolt Diameter	TPI	<i>ASTM A193 GR B7, B8, B16, B8M bolting & K-500 monel</i> with a bolt stress of 60,000 PSI
1/4	20	14
5/16	18	21
3/8	16	30
7/16	14	45
1/2	13	65
9/16	12	95
5/8	11	135
3/4	10	230
7/8	9	360
1	8	535
1 1/8	8	815
1 1/4	8	1,125
1 3/8	8	1525
1 1/2	8	1900
1 5/8	8	2540
1 3/4	8	3240
1 7/8	8	4075
2	8	4990
2 1/4	8	6665
2 1/2	8	8525
2 5/8	8	9525
2 3/4	8	10525
3	8	13760

6.4 Start-up Procedure

- 6.4.1 Prior to energizing the capacitor bank, make sure that all electrical connections are secured with proper torque as per chart in Section 6.3.
- 6.4.2 Connect power to capacitor bank (energize through upstream switch). Using an ammeter, measure capacitor current in each phase and verify that it is consistent (+/- 10%) with the current rating stated on the nameplate. Using a voltmeter, measure phase to phase voltage and verify that it is consistent (+/- 10%) with the voltage rating stated on the nameplate.
- 6.4.3 It is recommended that both the voltage and current be measured again after approximately 24 hours of operation.
- 6.4.4 During normal operation, fuse indicator lamps (when included) will be OFF. An illuminated lamp indicates that a fuse is open (blown). In the event that fuses in two or more of the phases are open, all lamps will be illuminated.

7.0 Electrical Connection Alternatives

Arteche power factor capacitor banks may be connected in a variety of locations, such as at the induction motor (which has low power factor), on a distribution panel, transformer secondary, substation secondary, main switchboard, etc. The benefits of improved power factor are realized upstream of the connection point.

7.1 Connection of Power Factor Capacitor on Load Side of Motor Overload Relay.

For connection at this location, you may use (per NEC) a non-fused capacitor bank. The overload relays will see lower current, so it is necessary to change the (full load current) setting of overload relays.

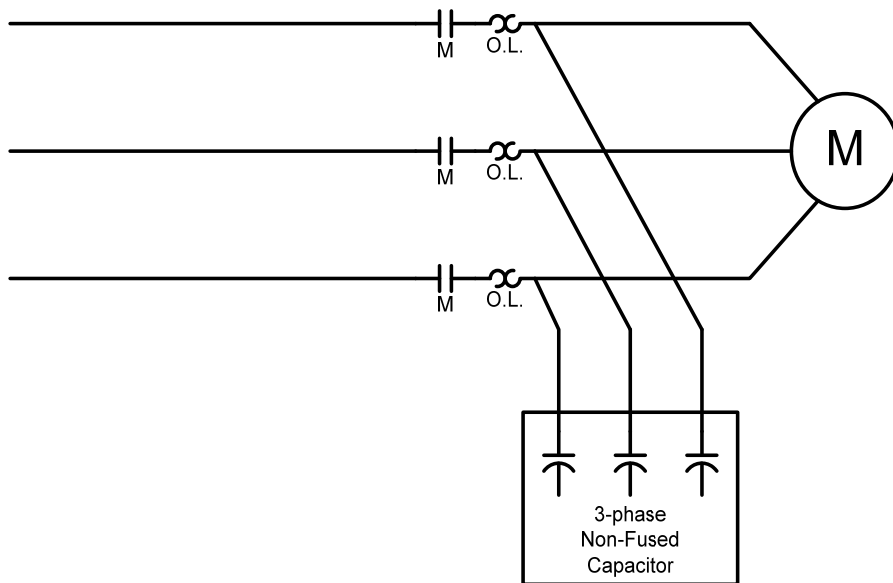

NOTE: Change overload relay full load current (FLA) setting:

Use this formula to calculate the new full load current that will be seen by the overload relays. Select overload relay (setting) based upon this new full load current value.

$$FLA_{new} = \frac{PF_{old}}{PF_{new}} * FLA_{nameplate}$$

7.2 Connection of Power Factor Capacitor on Line Side of Motor Starter, or Anywhere on Facility Power System (Distribution Panel, Transformer, Substation, etc.).

For connection at this location, it is necessary for the capacitor bank to be protected against over-current and to have its own means of disconnecting it from the supply. This requires either a disconnect switch and a set of fuses or a circuit breaker. For this point of connection, it is common to use either a capacitor bank with an internal circuit breaker or a fused capacitor bank with an external means of disconnect.

Fused Capacitor bank with external disconnect switch

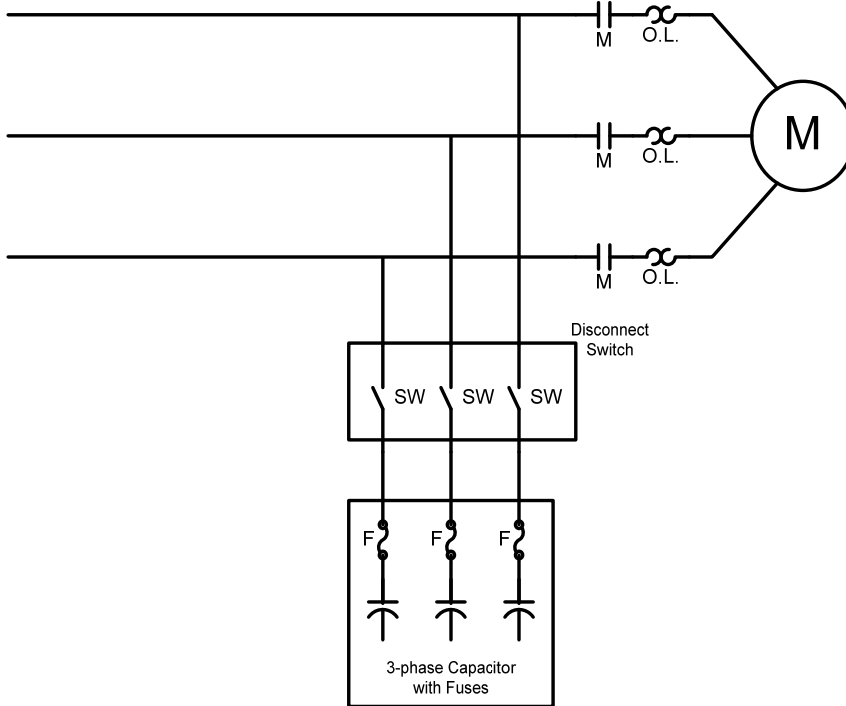

Capacitor bank with internal circuit breaker (serves as both disconnect & over-current protection)

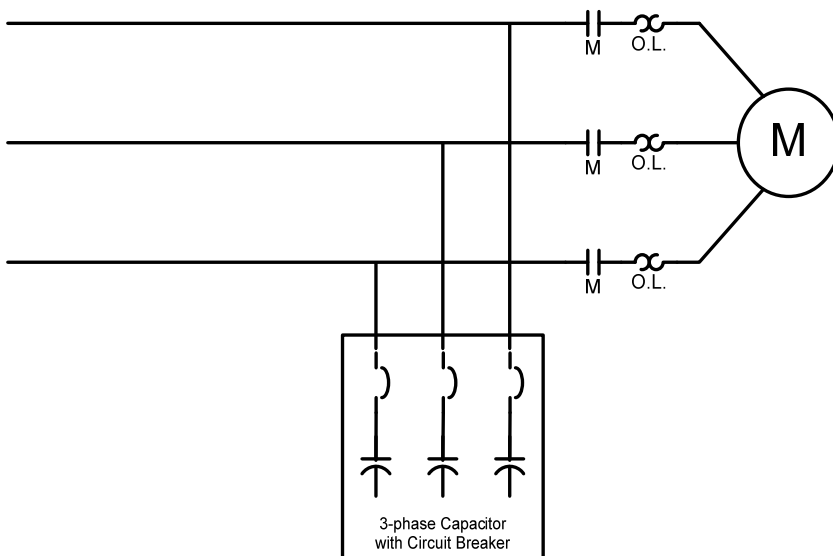

7.3 Typical Internal Capacitor Wiring Techniques.

Depending on the rated voltage and kVAr, capacitor cells used in a capacitor bank may be connected either in delta or wye configuration.

7.3.1 Examples of Delta Connected Capacitors.

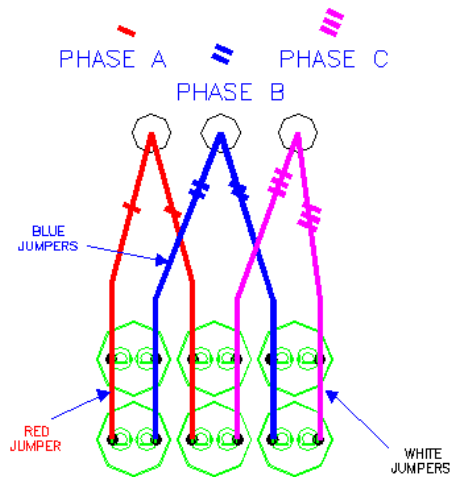

● CONNECTION POINT

CONNECTION FOR 6 CELLS

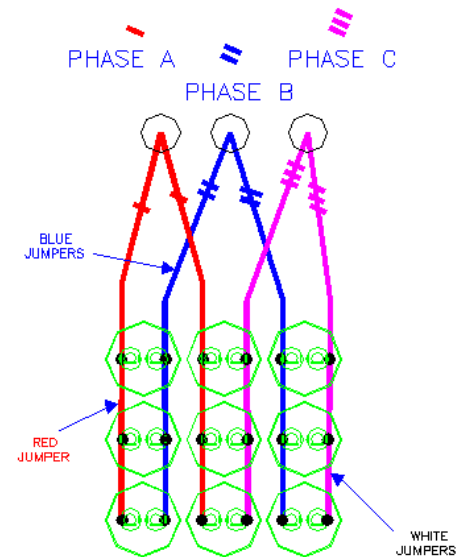

● CONNECTION POINT

CONNECTION FOR 9 CELLS

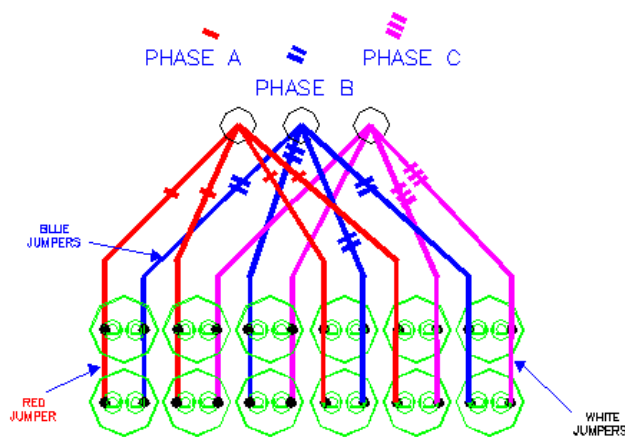

● CONNECTION POINT

CONNECTION FOR 12 CELLS

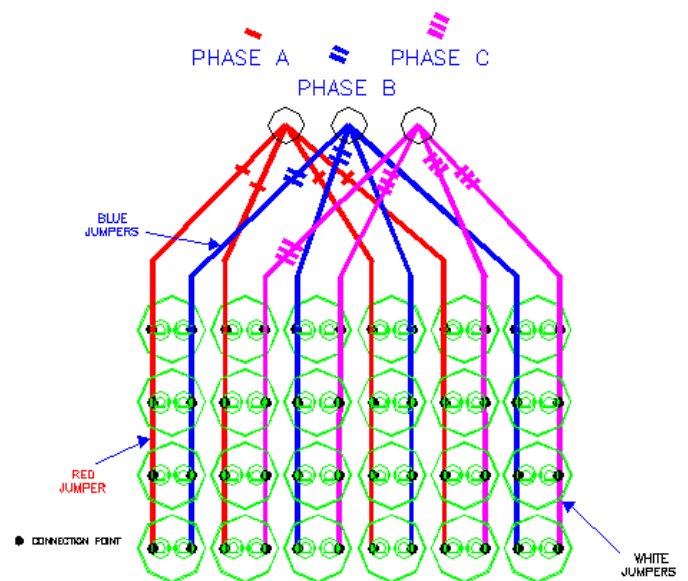

● CONNECTION POINT

CONNECTION FOR 24 CELLS

7.3.2 Examples of Wye Connected Capacitors.

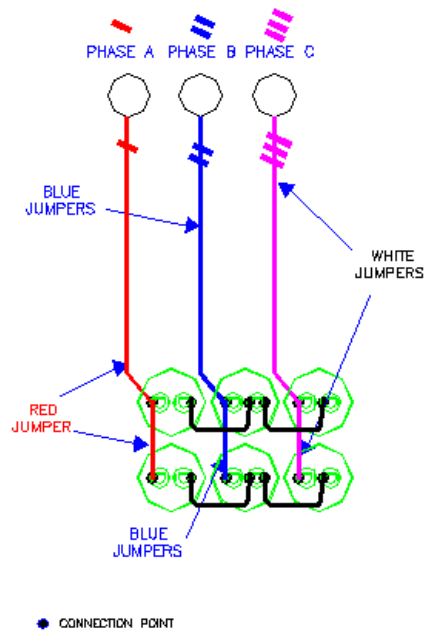

CONNECTION FOR 6 CELLS

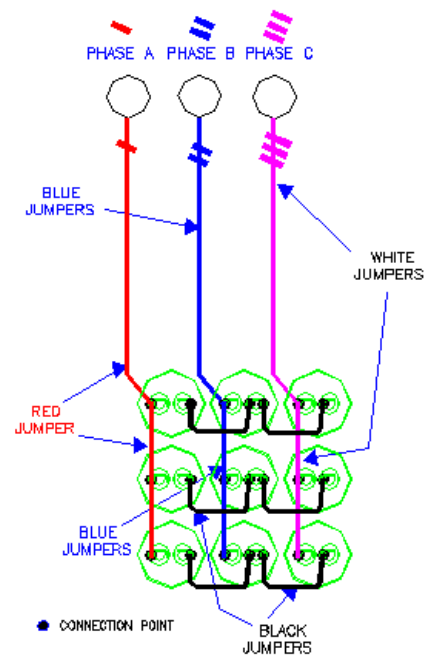

CONNECTION FOR 9 CELLS

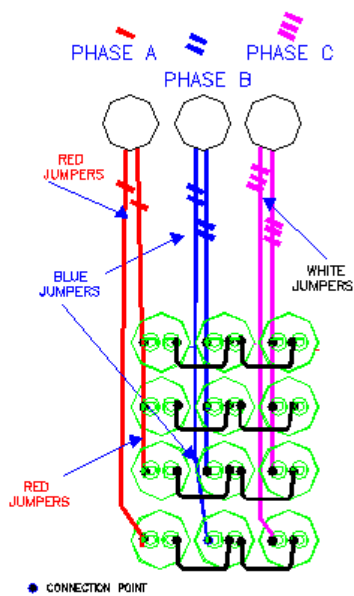

CONNECTION FOR 12 CELLS

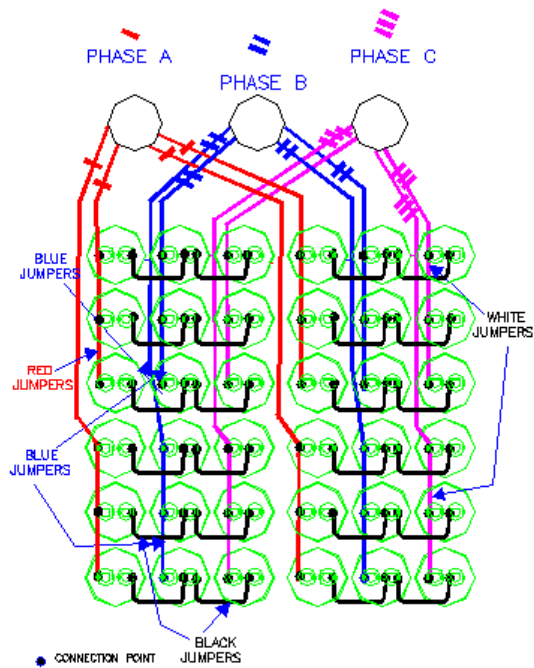

CONNECTION FOR 36 CELLS

8.0 General Specifications:

Electrical Characteristics	
Rated Voltage:	50Hz Ratings: 200, 240, 380, 415, 690 60Hz Ratings: 208, 240, 480, 600
Frequency:	50Hz and 60Hz available
Maximum Voltage:	110% of capacitor rating
Maximum Capacity:	135% of rated reactive power
Maximum Current:	135% of rated capacitor current
Maximum Harmonic Distortion:	10% THD-v at 25°C
Capacitor Type:	Metalized polypropylene; Self healing
Fuse AIC Rating:	200kA fuses typical
Internal Protection:	Internal pressure switch
Capacitor Connection:	DELTA is typical, WYE is available
Capacitance Tolerance:	+/- 4% of rated capacitance
Capacitor Discharge Device:	External resistors reduce voltage to <50V within 1 minute after de-energization.
Dielectric System:	Oil filled; non PCB
Dielectric Strength:	2 x V _(rated) + 1000V as per UL
Power Losses:	<0.5 watts per kVAr at 25°C
Design Service Life:	480,000 hours at 50C
Mechanical Characteristics	
Enclosure Type:	Metal (steel) enclosure
Capacitor Cell Case Type:	Aluminum case
Terminals:	Solid copper, pressure type
Environmental Characteristics	
Operating Temperature:	80C maximum capacitor cell external case temperature
Storage Temperature:	-40°C to + 65°C
Altitude:	1000 meters maximum (without derating)
Relative Humidity:	0-95% non-condensing
Standards and Approvals	
UL 810 (USA & Canada):	File # E227040
UL-508A (USA & Canada):	File # E311756

9.0 Technical Data:

9.1 Using PF capacitors on other power systems

Power factor capacitors may be applied to power systems with actual voltage equal to or less than the rated capacitor voltage but the effective kVAR will be reduced. Capacitors may also be used on either 50hz or 60hz systems but with possible derating. Use the chart below to determine the effective kVAR of a capacitor is used on system with voltage or frequency ratings that are different than the capacitor ratings. Never connect capacitors to a system with higher voltage than the capacitor rated voltage.

Capacitor Rating		Your Power System Rating												
Volts	Hz	Volts	600	480	440	415	380	380	240	240	220	220	208	200
		Hz	60	60	60	50	60	50	60	50	60	50	60	50
600	60		1.000	0.640	0.538	0.399	0.401	0.334	0.160	0.133	0.134	0.112	0.120	0.093
480	60			1.000	0.840	0.623	0.627	0.522	0.250	0.208	0.210	0.175	0.188	0.145
440	60				1.000	0.741	0.746	0.622	0.298	0.248	0.250	0.208	0.223	0.172
380	60					1.000	0.833	0.399	0.332	0.335	0.279	0.300	0.231	
240	60							1.000	0.833	0.840	0.700	0.751	0.579	
220	60									1.000	0.833	0.894	0.689	
208	60											1.000	0.770	

Example: A capacitor rated 100 kvar, 480V, 60Hz may be used on a 240 volt, 60Hz power system but it's effective capacity will be reduced as follows: $100\text{kVAR} \times 0.250 = 25 \text{ kVAR}$.

9.2 Physical data (Refer to enclosure drawings in section 9.5)

9.2.1 240V, NON-FUSED; Nema 1 indoor + outdoor enclosures

Non - Fused	KVAR	FLA	Size	Mass	Fuse	Switch	Field Wiring		
							Wire Size 90C Cu 30C ambient	Lug Capacity	Lug Tightening Torque (lb-in)
Catalog Number	@240 Volts 60Hz	Current (amps)	Enclosure Type	Weight (lbs)	Suggested Fuse rating Class J	Suggested Disconnect Switch Rating			
CFB 0002.5 240 N(X)	2.5	6.0	2B	11.88	10	30	14	14-6 AWG	35
CFB 0003.5 240 N(X)	3.5	8.4	2B	11.88	15	30	14	14-6 AWG	35
CFB 0004 240 N(X)	4	9.6	2B	11.88	20	30	14	14-6 AWG	35
CFB 0005 240 N(X)	5	12.0	2B	11.88	20	30	14	14-6 AWG	35
CFB 0006 240 N(X)	6	14.4	2B	13.86	25	30	14	14-6 AWG	35
CFB 0007.5 240 N(X)	7.5	18.0	2B	13.86	30	30	12	14-6 AWG	35
CFB 0010 240 N(X)	10	24.1	2B	13.86	40	60	10	14-2 AWG	45
CFB 0012.5 240 N(X)	12.5	30.1	2B	18.7	50	60	8	14-2 AWG	45
CFB 0015 240 N(X)	15	36.1	2B	18.7	60	60	8	14-2 AWG	45
CFB 0017.5 240 N(X)	17.5	42.1	2B	20.68	70	100	6	14-1/0	45
CFB 0020 240 N(X)	20	48.1	2B	20.68	80	100	6	14-1/0	45
CFB 0022.5 240 N(X)	22.5	54.1	4B	24.86	90	100	4	14-1/0	45
CFB 0025 240 N(X)	25	60.1	4B	24.86	100	100	4	14-1/0	45
CFB 0027.5 240 N(X)	27.5	66.2	4B	26.84	125	200	1/0	14-1/0	50
CFB 0030 240 N(X)	30	72.2	4B	26.84	125	200	1/0	14-1/0	50
CFB 0035 240 N(X)	35	84.2	4B	28.82	150	200	1/0	14-1/0	50
CFB 0040 240 N(X)	40	96.2	4B	30.8	175	200	1/0	14-1/0	50
CFB 0045 240 N(X)	45	108.3	5B	57.42	200	200	1/0	14-1/0	50
CFB 0050 240 N(X)	50	120.3	5B	59.4	200	200	2/0	14/2/0	50
CFB 0060 240 N(X)	60	144.3	8B	78.76	250	400	3/0	6 AWG - 250 MCM	275
CFB 0070 240 N(X)	70	168.4	8B	82.72	300	400	4/0	6 AWG - 250 MCM	275
CFB 0075 240 N(X)	75	180.4	8B	84.7	300	400	250MCM	6 AWG - 250 MCM	375
CFB 0100 240 N(X)	100	240.6	8B	105.6	400	400	2*2/0	2* (6AWG - 250MCM)	375
CFB 0125 240 N(X)	125	300.7	OPT	121	500	600	2*4/0	2* (6AWG - 250MCM)	375
CFB 0150 240 N(X)	150	360.9	OPT	132	600	600	2*250MCM	2* (6AWG - 250MCM)	375

9.2.2 240V, FUSED; Nema 1 indoor + outdoor enclosures

Non - Fused	KVAR	FLA	Size	Mass	Fuse	Switch	Field Wiring		
Catalog Number	@240 Volts 60Hz	Current (amps)	Enclosure Type	Weight (lbs)	Fuse Rating	Suggested Disconnect Switch Rating	Wire Size 90C Cu 30C ambient	Lug Capacity	Lug Tightening Torque (lb-in)
CFB 0002.5 240 N(X) FUS	2.5	6.0	2B	5.5	10	30	14	14-6 AWG	35
CFB 0003.5 240 N(X) FUS	3.5	8.4	2B	7.7	15	30	14	14-6 AWG	35
CFB 0004 240 N(X)FUS	4	9.6	2B	8.8	20	30	14	14-6 AWG	35
CFB 0005 240 N(X) FUS	5	12.0	2B	11.0	20	30	14	14-6 AWG	35
CFB 0006 240 N(X) FUS	6	14.4	2B	13.2	25	30	14	14-6 AWG	35
CFB 0007.5 240 N(X) FUS	7.5	18.0	2B	16.7	30	30	12	14-6 AWG	35
CFB 0010 240 N(X) FUS	10	24.1	2B	16.7	40	60	10	14-2 AWG	45
CFB 0012.5 240 N(X) FUS	12.5	30.1	2B	18.7	50	60	8	14-2 AWG	45
CFB 0015 240 N(X) FUS	15	36.1	2B	18.7	60	60	8	14-2 AWG	45
CFB 0017.5 240 N(X) FUS	17.5	42.1	4B	22.9	70	100	6	14-1/0	45
CFB 0020 240 N(X) FUS	20	48.1	4B	22.9	80	100	6	14-1/0	45
CFB 0022.5 240 N(X) FUS	22.5	54.1	4B	49.5	90	100	4	14-1/0	45
CFB 0025 240 N(X) FUS	25	60.1	4B	49.5	100	100	4	14-1/0	45
CFB 0027.5 240 N(X) FUS	27.5	66.2	4B	51.5	125	200	1/0	14-1/0	50
CFB 0030 240 N(X) FUS	30	72.2	4B	51.5	125	200	1/0	14-1/0	50
CFB 0035 240 N(X) FUS	35	84.2	5B	68.9	150	200	1/0	14-1/0	50
CFB 0040 240 N(X) FUS	40	96.2	5B	70.8	175	200	1/0	14-1/0	50
CFB 0045 240 N(X) FUS	45	108.3	8B	72.8	200	200	1/0	14-1/0	50
CFB 0050 240 N(X) FUS	50	120.3	8B	85.8	200	200	2/0	14/2/0	50
CFB 0060 240 N(X) FUS	60	144.3	8B	89.8	250	400	3/0	6 AWG- 250 MCM	275
CFB 0070 240 N(X) FUS	70	168.4	8B	93.7	300	400	4/0	6 AWG- 250 MCM	275
CFB 0075 240 N(X) FUS	75	180.4	OPT	95.7	300	400	250MCM	6 AWG- 250 MCM	375
CFB 0100 240 N(X) FUS	100	240.6	OPT	118.8	400	400	2*2/0	2* (6AWG- 250MCM)	375
CFB 0125 240 N(X) FUS	125	300.7	OPT	127.6	500	600	2*4/0	2* (6AWG- 250MCM)	375
CFB 0150 240 N(X) FUS	150	360.9	OPT	138.6	600	600	2 *250MCM	2* (6AWG- 250MCM)	375

	INSTALLATION, OPERATION AND MAINTENANCE MANUAL FOR Fixed Power Factor Capacitor Banks	August 04, 2010 Form No. M07-2012Staco / Aug 2010
--	---------------------------------------------------------------------------------------------	------------------------------------------------------

9.2.3 480V, FUSED; Nema 1 indoor + outdoor enclosures

9.2.4 480V, NON-FUSED; Nema 1 indoor + outdoor enclosures

9.2.5 600V, FUSED; Nema 1 indoor + outdoor enclosures

9.2.6 600V, NON-FUSED; Nema 1 indoor + outdoor enclosures

9.5 Enclosures

9.5.1 Size 2B – 8B Enclosures (Nema 1 and also for outdoor use) shown with optional blown fuse indicators

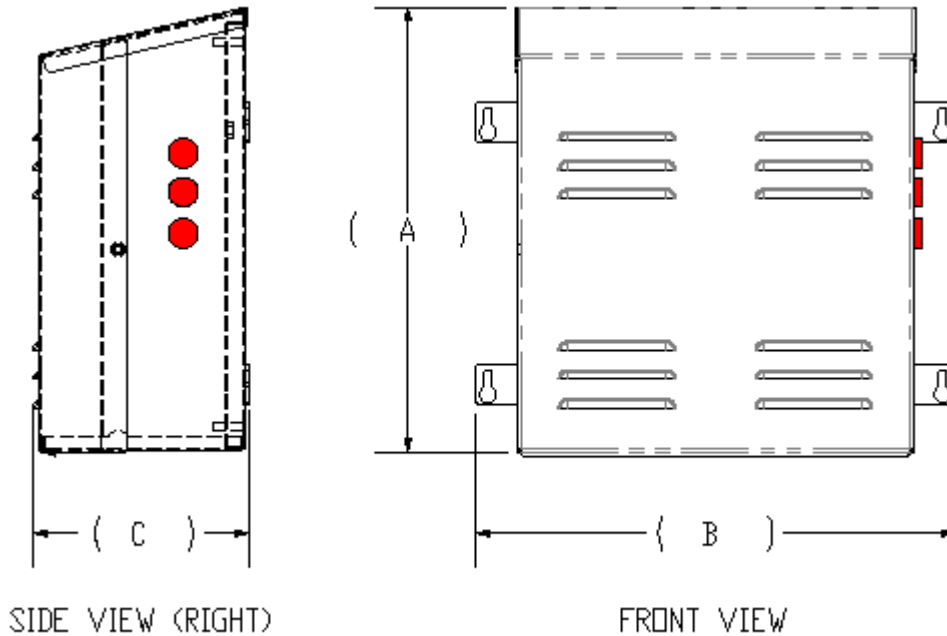

Approximate Enclosure Dimensions

Enclosure Size	A Height (inches)	B Width (inches)	C Depth (inches)
2B	14.0	15.0	6.5
4B	18.3	20.3	6.5
5B	20.9	20.7	6.5
8B	29.6	28.5	6.5

Mounting Slot (units are in millimeters)

Conversion (mm : inches)		
11mm	19mm	29mm
0.433 in	0.75 in	1.14 in

MOUNTING BRACKET

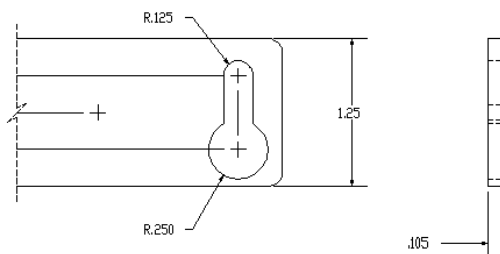

**9.5.2 Size OPT Enclosures (Nema 1 and also for outdoor use)
 shown with optional blown fuse indicators**

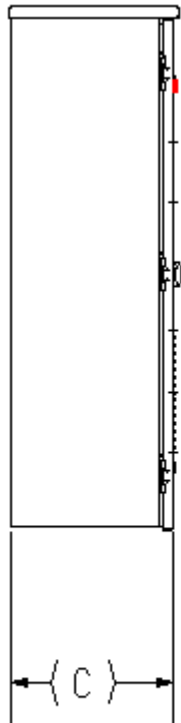

SIDE VIEW (LEFT)

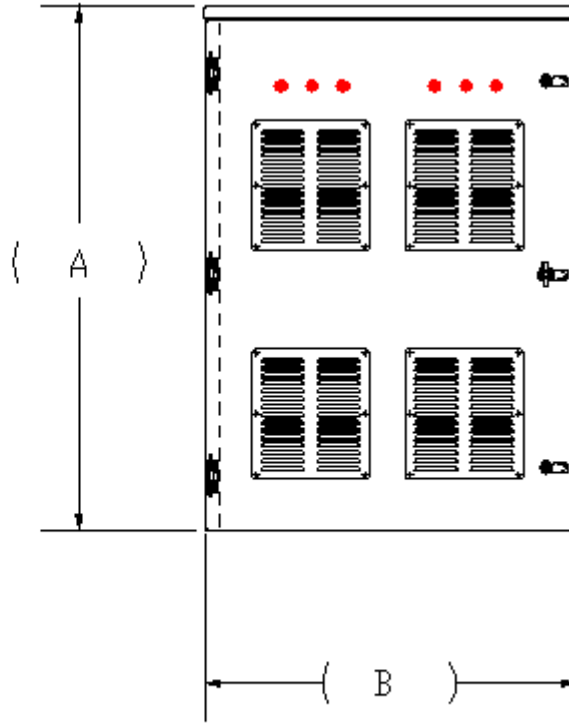

FRONT VIEW

Approximate Enclosure Dimensions

Enclosure Size	A Height (inches)	B Width (inches)	C Depth (inches)
OPT	42.0	30.0	12.0

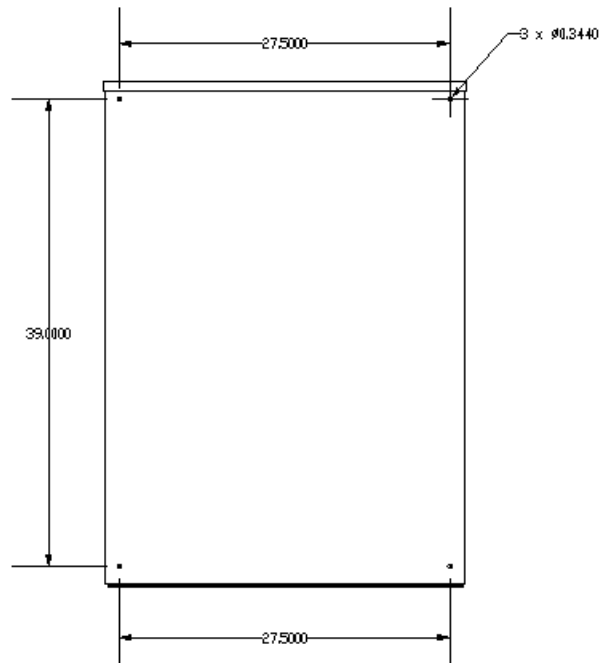

Rear view showing mounting holes

Mounting holes

Cabinet Mounting Holes (center to center)	
vertical	Horizontal
39.00 in	27.50 in

9.6.1 Capacitor Dimensions and Data:

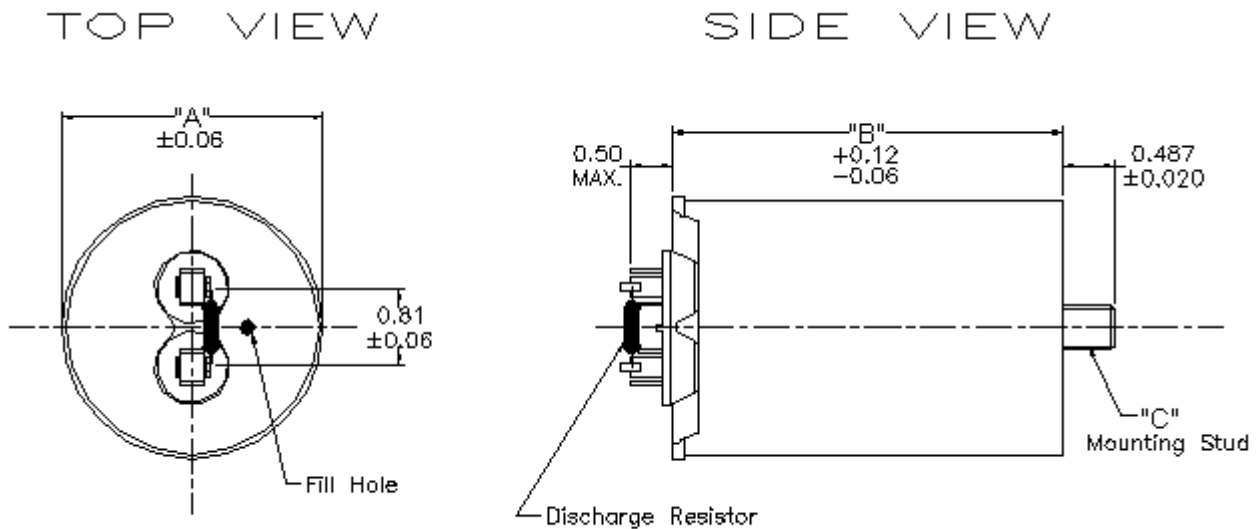

9.6.2 Individual Capacitor Cells - Dimensions and Weights.

PART NUMBER	DIMENSIONS (inch)			WEIGHT (Kg/Lb)
	"A"	"B"	"C"	
C1-1001 (47.8 μ F 240ACV)	2	4.37	M12	0.75/34
C1-1002 (79.8 μ F 240ACV)	2.52	4.37	M12	0.75/34
C1-2001 (38.4 μ F 346ACV)	2.52	4.37	M12	0.75/34
C1-2003 (57.0 μ F 346ACV)	2.52	4.37	M12	0.75/34
C1-2004 (72.1 μ F 346ACV)	2.52	4.37	M12	0.75/34
C1-3001 (11.9 μ F 480ACV)	2	3.37	M12	0.30/0.14
C1-3002 (20 μ F 480ACV)	2	3.37	M12	0.40/0.18
C1-3003 (39.8 μ F 480ACV)	2.52	4.37	M12	0.75/34
C1-3004 (50 μ F 480ACV)	2.52	4.37	M12	0.75/34

Note: M12 = 0.472 in diameter (use 0.500 dia. Mounting hole)

10.0 Maintenance

WARNING – Disconnect all electrical power from the capacitor prior to maintenance. Wait at least two minutes for capacitors to fully discharge prior to servicing this equipment. Extreme caution must be taken to prevent contact with high voltage during service of this equipment. Accidental contact with high voltage can result in personal injury or death.

Generally, Power Factor Capacitor Banks are considered to be maintenance free. During the course of normal operation, the capacitor cells will experience minute levels of expansion and contraction due to fluctuations in operating and ambient temperatures. Over time, the capacitance value may decrease, especially when self-protection occurs.

The following inspections should be made during regular maintenance intervals, or semi-annually.

- Periodically inspect the individual capacitor cells for bulging. If the top (terminal area) is bulging, then it is likely that the pressure switch has opened and the capacitor is no longer operational. For proper performance, any failed capacitor cells should only be replaced with direct factory replacements.



- To verify the general condition of the capacitors, take a current measurement in each capacitor phase. A discrepancy in current between phases may indicate a failed capacitor cell. For proper performance, any failed capacitor cells should only be replaced with direct factory replacements.
- Remove any dust and dirt that may have accumulated within your capacitor cabinet. Check to assure that the enclosure is properly and adequately ventilated.
- Routinely check to see that wire terminations are securely fastened to capacitor terminals.
- Routinely check torque on all terminations. Verify they are in compliance with the torque chart in Section 6.3..

The following maintenance items require the capacitor to be energized and should be performed only by trained and qualified personnel.

WARNING – Only qualified electricians should handle the installation of this capacitor bank, otherwise electric shock or fire may occur.

- Measure the voltage between each of the phases and verify it is within +/-10% of the voltage rating stated on the nameplate. Measure the current in each capacitor phase and verify it is within +/-10% of current rating stated on the nameplate.

11.0 Troubleshooting Guide

Symptom	Problem	Solution
Indicator lamp glowing	Blown fuse	Disconnect power to capacitor bank. Wait two minutes before continuing. Locate the blown fuse and its associated capacitor cell(s). Inspect capacitors(s) for bulging or other indication of failure. Replace blown fuse and failed capacitors. Contact factory for replacement capacitors.
Capacitor phase currents are not balanced	Blown fuse or failed capacitor	Identify blown fuse and/or failed capacitor (look for bulge at top) and replace using exact replacement. Contact factory for replacement capacitors.
Capacitor failure	Harmonics	Apply harmonic filter to harmonic producing load(s) or replace capacitor bank with detuned capacitor bank to minimize the flow of harmonic currents in capacitor. Contact Artech for harmonic filters and detuned capacitor banks.
Blown fuse	Harmonics	Apply harmonic filter to harmonic producing load(s) or replace capacitor bank with detuned capacitor bank to minimize the flow of harmonic currents in capacitor. Contact Artech for harmonic filters and detuned capacitor banks.

For technical support and application engineering assistance, please contact:

ARTECHE PQ, INC.
16964 West Victor Road
New Berlin, WI 53151
Phone: 1-262-754-3883
Fax: 1-262-754-3993