



INSTALLATION, OPERATION AND
MAINTENANCE MANUAL FOR
LOW VOLTAGE
Active Harmonic Filters

Rev. 5, January 27, 2012

Type AHF

Active Harmonic Filter

User's Manual

16964 West Victor Road
New Berlin, WI 53151
(262) 754-3883 • Fax: (262) 754-3993
Web site: www.artechepq.com

	INSTALLATION, OPERATION AND MAINTENANCE MANUAL FOR LOW VOLTAGE Active Harmonic Filters	Rev. 5, January 27, 2012
--	---	--------------------------

Page Intentionally Left Blank

CONTENTS

Subject	Page
PREFACE	1
SAFETY	2
FUNCTIONS AND OPERATING PRINCIPLES	3
Functions	3
Components	4
Brief Description of Components	5
Ripple Current Filter Module	5
Pre-Charge Electromagnetic Contactor Module	6
High Frequency Inductor-Capacitor Module	6
IGBT Power Converter Module	7
DC Capacitor Module	7
STRUCTURE SCHEMATIC DIAGRAM	8
SPECIFICATIONS	9
General Specifications	9
Mechanical Specifications	9
Electrical Specifications and Ratings	10
Circuit Breaker Selection	11
Harmonic Compensation Ability	11
REACTIVE POWER SPECIFICATIONS, REQUIREMENTS FOR AHF OPERATION	12
AHF AMPERE SELECTION & MAXIMUM CT PRIMARY CURRENT	13
VOLTAGES ABOVE 480 VOLTS	14
FILTER INSTALLATION AND WIRING	15
Location and Installation	15
General Requirements for Ventilation	18
Wiring Connections	19
Current Transformer Installation and Wiring	20
Optional Current Transformers	24
Additional Reference Drawings, Connection Layouts and Dimensions	25
OPERATION	35
Control Panel	35
Functional Descriptions	36
Control Panel LED Indicator Status	36
Start-up Procedures	37
Shutdown Procedures	39
Silencing the Alarm	39
On-Site Tuning Procedures for Optimum Performance	40
Positions of LEDs and Switches on PCB APJ15	41
Function Settings & Energy Saving	42
Configuration Procedures for Modifying Harmonic Selection	43
Dry Contacts	45
Clearing Error Status and Troubleshooting	46
TROUBLESHOOTING	45
BASIC INSTALLATION AND MAINTENANCE	49

ILLUSTRATION CONTENTS

Drawing 1-1	System Structure Schematic Diagram	8
Drawing 2-1	Install Top Cover of AF-0025&AF-0050	15
Drawing 2-2	Install Top Cover of AF-0100&AF-0150	16
Drawing 2-3	Install Top Cover of AF-0200	23
Drawing 2-4	2CTs Wiring Schematic Diagram at Load Side	23
Drawing 2-5	2CTs Wiring Schematic Diagram at Power Side	20
Drawing 2-6	AF-0025 & AF-0050 with LCD Control & Dimensions Diagram.....	29
Drawing 2-7	AF-0025 & AF-0050 Wiring Position Schematic Diagram.....	30
Drawing 2-8	AF-0100 & AF-0150 with LCD Control & Dimensions Diagram	31
Drawing 2-9	AF-0100 & AF-0150 Wiring Position Schematic Diagram.....	32
Drawing 2-10	AF-0200 LCD Control & Display Panel Physical Dimensions Diagram ..	33
Drawing 2-11	AF-0200 Wiring Position Schematic Diagram.....	34
Drawing 3-1	Control Panel Diagram	35
Drawing 3-2	Positions of LEDs and Switches on PCB APJI5	41
Chart 3-2	SW1 Setting (for Harmonic Selection).....	43
Chart 3-3	Harmonic Compensation Setting Description (SW2 Setting).....	44
Chart 3-4	Dry Contacts Description	45
Drawing 3-3	Positions of Dry Contacts on PCB APJK2	45

PREFACE

We thank you for the trust in selecting the **ARTECHE** Type AHF Active Harmonic Filter.

This equipment complies with UL 508 and is authorized to use the UL marking.



The purpose of this user's manual is to describe the operating principles for the **ARTECHE** Active Harmonic Filter and providing users with necessary procedures for the installation and operation of the system.

SAFETY

 CAUTION!	System installation, operation and maintenance should only be carried out by authorized and trained personnel, adhering to local AND international regulations.
--	--

 DANGER	Before any maintenance to the Active Harmonic Filter (AHF), be certain that the power switch is OFF, and wait for at least FIVE minutes to ensure any residual current has been completely discharged from the DC Capacitor Module.
--	--

The following precautions should be observed at all times during the installation, operation, maintenance or calibration of the AHF:

1. Ensure the AHF has been properly grounded before the switch is turned on. Poor grounding will cause malfunction or possible electrical shock.
2. Maintenance should be conducted with care to avoid possible electrical shock. It is strongly advised that voltage levels of circuits be checked, and that all stored-energy components have been fully discharged before maintenance is performed. Safety goggles should be worn throughout the maintenance process.
3. If the AHF has been incorrectly installed, harmonic current and voltage may be applied onto the power system resulting in damage to the equipment and other systems.
4. Incorrect operating methods may cause damage to equipment components and degrade the system's performance.
5. An improper shutdown (*switch-off*) procedure of the AHF may cause damage to the equipment. See Section – “**Shutdown Procedures**” in this manual.
6. Replacement of any components or parts should be done by an authorized technician.

FUNCTIONS AND OPERATING PRINCIPLES

FUNCTIONS

The AHF is a solid-state power converter that provides the following advantages:

- Minimizes harmonic currents from non-linear loads.
- Compensates reactive power factor of lagging loads.
- Acts as a virtual damping resistor to prevent possible harmonic resonance.

The AHF significantly reduces the upstream harmonic distortion because the AHF is a more attractive source of harmonic currents than the utility power system. The AHF will supply the harmonic currents demanded by the non-linear loads and typically achieves a 10:1 reduction of each individual harmonic. By significantly reducing the harmonic currents in the circuit, there will be

1. No risk of harmonic resonance.
2. Significant reduction of current waveform distortion.
3. Significant reduction of the voltage waveform distortion.
4. Reduction of voltage drop on transformers & cables.
5. Reduction of temperature rise on transformers & cables.
6. Reduced true RMS current.
7. Improved power factor.

 CAUTION!	<p>The AHF is not recommended with a load that has a fast rising current rate (di/dt), such as that of a rectifier employing phase control with extra low inductance rating. Loads with high di/dt rates may cause the AHF to stop operating. In certain applications where there is equipment having similar characteristics, such a load will generate high-frequency current. Add a line reactor (minimum 3% impedance) to these loads prior to installing the Active Harmonic Filter.</p> <p>Power factor correction capacitors and certain types of passive harmonic filters, etc. may also affect the normal operation of the AHF or cause it to shut down.</p> <p>Note location of CT placement found in the manual on pages 22-23.</p>
--	--

COMPONENTS

The **ARTECHE** AHF provides three phase harmonic current compensation. The main components of the AHF are as follow:

- ✓ A ripple current filter module. This module's main function is to absorb the high frequency ripple current. Fixed reactive power is provided by capacitors in the Inductor-Capacitor Module.
- ✓ A pre-charge electromagnetic contactor module. This module helps to limit the amplitude of the inrush current when DC capacitor set is charging.
- ✓ A high frequency inductor-capacitor module. This module acts as the power transmission interface component between power converter and power system.
- ✓ An Isolated **G**ate **B**ipolar **T**ransistor (IGBT) power converter module. This module transforms the harmonic energy from the connected power system and regenerates an equal, but opposite phase shifted harmonic current back to the power system. This regenerated energy will cancel the harmonic produced by the power system.
- ✓ A DC capacitor module. This module stores energy taken from the power system before the IGBT Converter can use it to regenerate the opposite phase shifted compensating harmonic current.

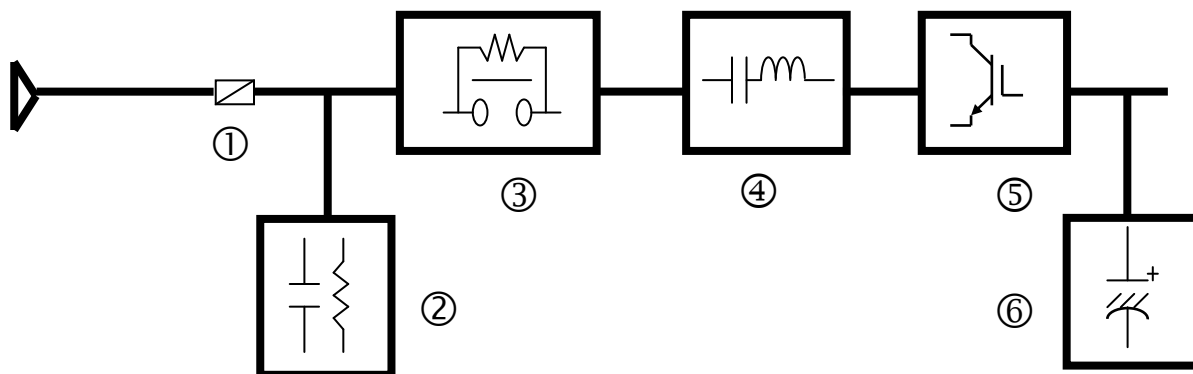

- (1) High-Speed Fuse
- (2) Ripple Current Filter Module
- (3) Soft-start Electromagnetic Contactor Module
- (4) High Frequency Inductor-Capacitor Module
- (5) IGBT Power Converter Module
- (6) DC Capacitor Module

BRIEF DESCRIPTION OF COMPONENTS

This section describes the working principles of the main components inside the ARTECHE Type AHF Active Harmonic Filter.

RIPPLE CURRENT FILTER MODULE

The ripple current filter is shunt-connected at the output terminals of the AHF. Its primary function is to absorb high frequency ripple current. Its components consist of the following:

- Parallel/Series link resonance filter.
- Over-current protection relay (OL1).
- Abnormal trip control device.

The over-current protection relay (OL1) is incorporated to protect the AHF. Either adverse system conditions, interference with VFDs that do not have internal reactors, or a malfunctioning IGBT power converter may generate a large amount of high frequency current into the ripple current filter. This will cause the over-current protection relay to trip, thus shutting down the AHF system to prevent further damage to the entire the AHF system.

PRE-CHARGE ELECTROMAGNETIC CONTACTOR MODULE

The main function of this module is to inhibit inrush current while the DC capacitor module is charging. When the voltage of the DC capacitor reaches its default value, the AHF will then be switched on to its normal operating mode, thus removing the pre-charge resistor from the circuit. The main components for pre-charge electromagnetic contactor are as followings:

- Current-limiting resistor
- Electromagnetic contactor

This module inhibits the inrush current going through the IGBT power converter and into the DC capacitor module within a pre-determined and acceptable level. After switching on the AHF, the electromagnetic contactor will close to bypass the current-limiting resistor, and connecting the IGBT power converter directly to the power system.

HIGH FREQUENCY INDUCTOR-CAPACITOR MODULE

The inductor and capacitor are the power transmission interface components between the IGBT power converter and the connected power system. This module also compensates the reactive power to improve the lagging power factor.

The main components of the High Frequency Inductor-Capacitor Module are:

- High frequency response inductor.
- High frequency response capacitor.
- Current transformer.

The current transformer is used to feedback the harmonic compensating current to a control circuit, this will allow the AHF to perform high-speed compensation and ensure a current-limit if the harmonic energy exceeds its capacity.

Under normal working conditions, the ripple current filter will also provide partial reactive power factor to improve lagging power factor. The capacitors in this module supply a fixed amount of reactive power when the filtering is on.

IGBT POWER CONVERTER MODULE

The IGBT power converter is the major architecture of the AHF in terms of performing the cancellation of the harmonic current (I_{Lh}) generated by the connected non-linear load. The IGBT power converter makes use of this harmonic energy (I_{Lh}) as an initial power to produce an opposite phase shifted harmonic current waveform (I_E). This waveform is then re-injected into the connected power system to cancel the existing harmonic distortions (I_{Lh}), ensuring a near perfect sine waveform (I_s) returned to the power system conductors.

The main components of the IGBT power converter module are:

- IGBT transistor bridge
- Driver circuit
- Snubbers

The electronic bridge of the power converter is made up of isolated gate bipolar transistors (IGBT). It utilizes **Pulse Width Modulation (PWM)** technology to drive the IGBTs to produce the compensating current waveform. Built in snubbers are used with the IGBTs for protection from spikes when the power converter is in operation.

DC CAPACITOR MODULE

DC capacitor module stores the energy (I_{Lh}) generated by the connected power system to be used by the IGBT power converter for re-generation of the opposite phase shifted compensating harmonic current waveform (I_E). The storage and release of energy of the DC capacitor module is electrically control by the IGBT power converter.

The DC capacitor module is made up of specific magnitude of capacitance (μF) to supply the required harmonic energy. Multiple DC capacitors are connected electrically in parallel to achieve the total required capacitance.

SCHEMATIC DIAGRAM

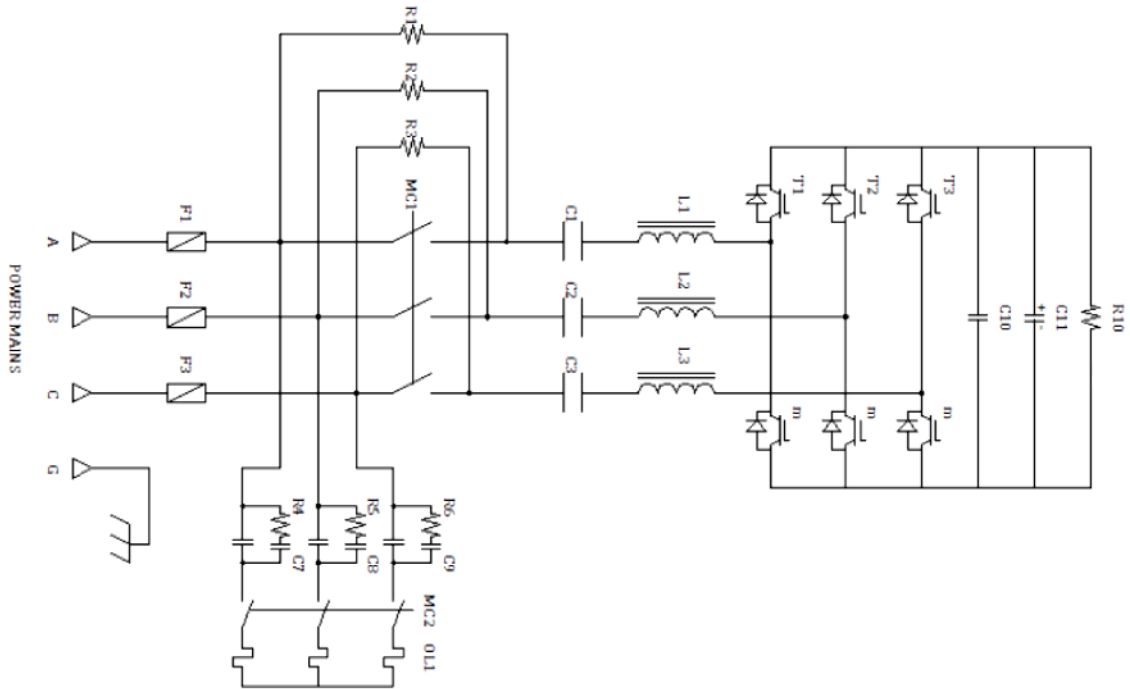

Drawing 1-1 AHF System Structure Schematic Diagram

SPECIFICATIONS

General Specifications

Equipment storage temperature	-20°C to +70°C
Operating Temperature	+12°C to +25°C (Recommended Range), + 0°C to +40°C (Tolerated Range)
Relative Humidity	< 95%
Operating Altitude	< 1000 m
Reference Harmonic Standard	EN 61000-3-4 , IEEE 519-1992
Reference Design Standard	EN60146
Safety Standard	EN50178, UL508, CUL508
Electromagnetic Compatibility	EN55011, EN50081-2, EN61000-4-2, EN61000-4-3, EN61000-4-4, EN61000-4-5, EN61000-4-6, EN61000-6-2, FCC Part 15, ANSI C62.41, IEEE587
Enclosure Paint	Light Beige, Textured surface RAL9001

Mechanical Specifications

Filters rated above 200 amps (shaded area) are supplied as multiple units of lower current rated filters.

This table indicates how units are generally constructed. Other multiple unit configurations can be provided.

Filter Rating	Actual Filter Units	Style	Height (inches)	Width (inches)	Depth (inches)	Weight (pounds)
25	1 x 25A	Wall	36	16.2	15.4	121
50	1 x 50A	Wall	36	16.2	15.4	154
100	1 x 100A	Floor	78	24	32	595
150	1 x 150A	Floor	78	24	32	661
200	1 x 200A	Floor	78	48	32	1190
250	1 x 100A and 1 x 150A	Floor	78	48	32	1256
300	2 x 150A	Floor	78	48	32	1322
400	2 x 200A	Floor	78	96	32	2380
450	3 x 150A	Floor	78	72	32	1983
600	4 x 150A	Floor	78	96	32	2644
750	5 x 150A	Floor	78	120	32	3305
800	4 x 200A	Floor	78	192	32	4760
900	6 x 150A	Floor	78	144	32	3966
1000	5 x 200A	Floor	78	240	32	5950
1200	6 x 200A	Floor	78	288	32	7140

ELECTRICAL SPECIFICATIONS AND RATINGS

Line Voltage	V	208 / 240 / 380 / 415 / 480 / 600 / 690 (-10%, +15%)
Phase/Wires		3 phase; 3 wires
Frequency	Hz	50Hz or 60Hz (±3 Hz)
Compensated Harmonic Orders		<u>Global:</u> Use this to compensate for all harmonic frequencies from 3 rd to 51 st . <u>Selective Compensation:</u> Use this for simultaneous compensation for up to four individual harmonic frequencies (choose from 3, 5, 7, 11, 13, 17, 19, 23, 25). <u>High Order compensation:</u> compensates 15 th – 51 st harmonic
Harmonic attenuation ratio		Typically 10:1 when load current is <50% THD-i
Transient Response Time	msec	< 20
Inrush Current		No more than rated current
Current Limitation		Yes, at full correcting amperes; no overload
Pre-charge time	Sec	10

Electrical Ratings Data

Filter Rating	Compensating Current (amps)	* Maximum Bus Current at CT location	* Maximum Bus Current at CT location	Recommended Upstream Circuit Breaker	Heat Losses (kW)	Audible Noise (1m) (dBA)
25	25	250 Arms	375A peak	35 A	0.55	60
50	50	500 Arms	750A peak	65 A	0.95	60
100	100	1000 Arms	1500A peak	125 A	2.00	63
150	150	1500 Arms	2250A peak	200 A	3.00	63
200	200	2000 Arms	3000A peak	250 A	4.10	65
250	250	2000 Arms	* 3000A peak	1x 125 A 1x 200 A	5.00	65
300	300	2000 Arms	* 3000A peak	2x 200 A	6.00	65
400	400	2000 Arms	* 3000A peak	2x 250 A	8.20	65
450	450	2000 Arms	* 3000A peak	3x 200 A	9.00	65
600	600	2000 Arms	* 3000A peak	3x 250 A	12.30	65
750	750	2000 Arms	* 3000A peak	5x 200 A	15.00	65
800	800	2000 Arms	* 3000A peak	4x 250 A	16.40	65
900	900	2000 Arms	* 3000A peak	6x 200 A	18.00	65
1000	1000	2000 Arms	* 3000A peak	5x 250 A	20.50	65
1200	1200	2000 Arms	* 3000A peak	6x 250 A	24.60	68

* with standard 2000:1 CT. Other ratios are available but require factory modification. See page 22.

CIRCUIT BREAKER SELECTION

The peak current associated with harmonic currents are higher than for a sinusoidal current waveforms. Circuit breakers should be selected based on AHF ampere rating X 1.25. Filters rated above 200 amps are supplied as multiple units of lower current rated filters (see chart on page 9). Each filter unit requires its own circuit breaker.

Filter Ampere Rating	Circuit Breaker Rating
25	35 A
50	65 A
100	125 A
150	200 A
200	250 A

COMPENSATION ABILITY

The compensation ability of the AHF is defined in terms of **Harmonic Attenuation Ratio (HAR)**.

$$HAR = I_{Lh} / I_{Sh}$$

HAR : Harmonic attenuation ratio

I_{Lh} : Harmonic current at load side

I_{Sh} : Harmonic current at power source side

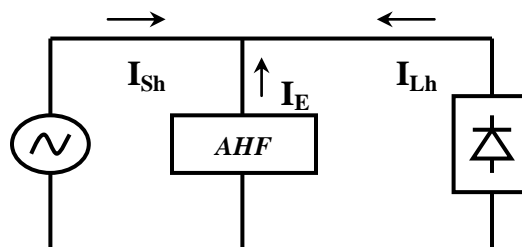

Note: All measurements should be carried out when the AHF is functioning normally.

Typically, the AHF will attenuate the current at each harmonic frequency by 10:1. In cases where total bus current distortion is less than 50% THD-I, this will achieve residual harmonic current distortion of approximately $\leq 5\%$ THD-I and also meet 5% TDD.

REACTIVE POWER SPECIFICATIONS

Reactive Power (kVAR)

	25A	50A	100A	150A	200A
208V	2.9	5.8	11.6	17.3	23.1
220V	3.2	6.5	13.0	19.4	25.9
380V	9.9	19.7	39.5	59.2	79.0
480V	15.6	31.3	62.5	93.8	124.8

Nominal Reactive Current (Amperes) at 60 Hz

	25A	50A	100A	150A	200A
208V	8	16	32	48	64
220V	8.5	17	34	51	68
380V	15	30	60	90	120
480V	18.8	37.4	75	113	150

REQUIREMENTS FOR PROPER AHF OPERATION, PERFORMANCE

- 1) Select AHF rated 25% larger than actual RMS harmonic current. This compensates for any error in measurement and handles increased loading conditions.
- 2) It is better to apply multiple smaller rated AHF units closer to the harmonic producing loads on smaller down stream buses, rather than to attempt to place one large filter on a high current bus. Our standard CTs are rated for this type of application.
- 3) AC or DC drives are required to have a minimum effective impedance of 3% through the use of ac line reactors, dc chokes, or isolation transformers, in order to achieve proper operation and performance.
- 4) For proper startup and operation of the AHF, system voltage distortion must be lower than 10% THD-v when AHF unit is OFF.
- 5) For proper start-up and functioning of the AHF, system voltage distortion should be lower than 5% THD-v when the AHF unit is ON.
- 6) **WARNING:** Do not connect AHF unit and CTs to a system bus with current that exceeds 10X the ampere rating of the AHF unit. See maximum peak current table below. Example: 100A filters may be applied on 1000A bus or less.
- 7) **WARNING:** Do not connect AHF unit to "corner Grounded Delta Power System".
- 8) **WARNING:** Do not use Source Side CT connections when using multiple AHF units in parallel.

AHF (AMPERE) SELECTION

The **ARTECHE** AHF compensates harmonic current automatically. Generally, there is no need to measure the impedance of the power system, or to analyze the load harmonic spectrum. The ampere size selection is based on the known estimated load harmonic current amplitude (I_{Lh}) to be compensated. Select the AHF model which has the appropriate voltage and frequency ratings and output compensating current rating **greater than** that of the I_{Lh} .

NOTE:

Generally as a rule of thumb, we recommend a 25% higher rating than the I_{Lh} to be compensated. For example, if the known load harmonic current amplitude is 40 Amps, the appropriate rating of the AHF should be 50 Amps. In the event the real values of the I_{Lh} are higher than the estimated ones, or the I_{Lh} increases due to additional loads, there is no overload risk on the existing AHF that has been selected.

The AHF has current limit capability up to its full rated compensating capacity, thus it will not shut down or malfunction, but will continue to operate in full compensating mode. In such cases, additional AHFs can be added in parallel to meet the increase of the I_{Lh} value. Up to six AHF units may be connected in parallel. Each must have its own set of CTs.

NOTE: FOR BEST RESULTS LOCATE THE AHF CLOSE (ELECTRICALLY) TO THE HARMONIC PRODUCING LOADS.

MAXIMUM CT PRIMARY CURRENT

Caution must be taken to assure that the CT's and AHF controller do not become overloaded by the total RMS current flowing on the conductor serving as the CT primary. Locate the CTs on a conductor that is close to the load (electrically) and having peak current within the capabilities of the CT and AHF controller. Although the circuit harmonic current I_{Lh} may be within the rated amperes of the AHF, it is important to make sure that the true RMS bus current (primary of CT) does not exceed the capability of the CTs or controller. If the CTs are connected to a bus where excessive current is flowing (RMS or peak), then the AHF controller will become overloaded and damage may occur to the AHF. Refer to Maximum CT Current Table on page 21.

NOTE: Consult factory for larger rated CTs, also see page 24.

VOLTAGES ABOVE 480 volts (600V or 690V)

Arteche Type AHF active harmonic filters may be applied to power systems with voltages having greater than 480 volts, when an interposing transformer is used. The filter will then consist of a standard 480V filter plus a separately mounted, separately enclosed auto-transformer. This auto-transformer can be supplied by Arteche or may be sourced individually by the filter user. For proper operation and performance, the step-up auto-transformer must meet specifications indicated below.

Arteche Typical Auto-Transformer Specifications

PARAMETER	600V, 60HZ	690V, 50HZ
Primary voltage	480V, +/-5%	415V, +/- 5%
Secondary voltage	600V, +/- 5%	690V, +/- 5%
No. of phases	3ph, 3-wire	3ph, 3-wire
Frequency	60 Hz	50 Hz
Impedance	~1%	~1%
Regulation	1%	1%
Excitation current	~5% (10% max)	~5% (10% max)
Cooling	Natural convection	Natural convection
Max. Ambient Temp	40°C	40°C
Temperature rise	135°C	135°C
Insulation system	200°C	200°C

ARTECHE TYPICAL AUTO- TRANSFORMER DIMENSIONS (600V, 60HZ)

(For reference only – consult factory for actual dimensions)

FILTER Rating	TRANSFORMER KVA	OPEN CORE & COIL		N1 & N3R ENCLOSED	
		SIZE	WEIGHT	SIZE	WEIGHT
25 AMP	32	8H X 12W X 10D	105 LBS	18H X 14W X 14D	150 LBS
50 AMP	63	11H X 14W X 16D	150 LBS	26H X 18W X 18D	195 LBS
100 AMP	125	12H X 15W X 16D	220 LBS	28H X 18W X 18D	275 LBS
150 AMP	187	14H X 15W X 16D	310 LBS	34H X 24W X 20D	430 LBS
200 AMP	250	15H X 17W X 16D	360 LBS	34H X 24W X 20D	515 LBS

NOTE: AHF'S ARE DETRATED OVER 480 AMPS. FOR EXAMPLE, AT 600VAC, THE AHF IS DERATED 20%. A 200 AMP FILTER AT 600VAC WILL BE RATED FOR 160 AMPS.

INSTALLATION AND WIRING

LOCATION AND INSTALLATION (NEMA 1 ENCLOSURES)

To ensure the proper operation and to enhance the operating life span of the AHF, it is recommended to install the AHF in a dust free environment where temperature and humidity are maintained at the values specified in the characteristics and specification section (page 9). Cooling fans are built-in to dissipate heat from the AHF, it is important to avoid any obstruction to the front, top, and base ventilation louvers of the AHF at all times.

To prevent anything from dropping into the AHF and damaging the components inside, install the top cover and secure it to the enclosure with the screws provided. Drawings 2-1 to 2-3 below show the installation of the top cover onto the various models of AHFs.

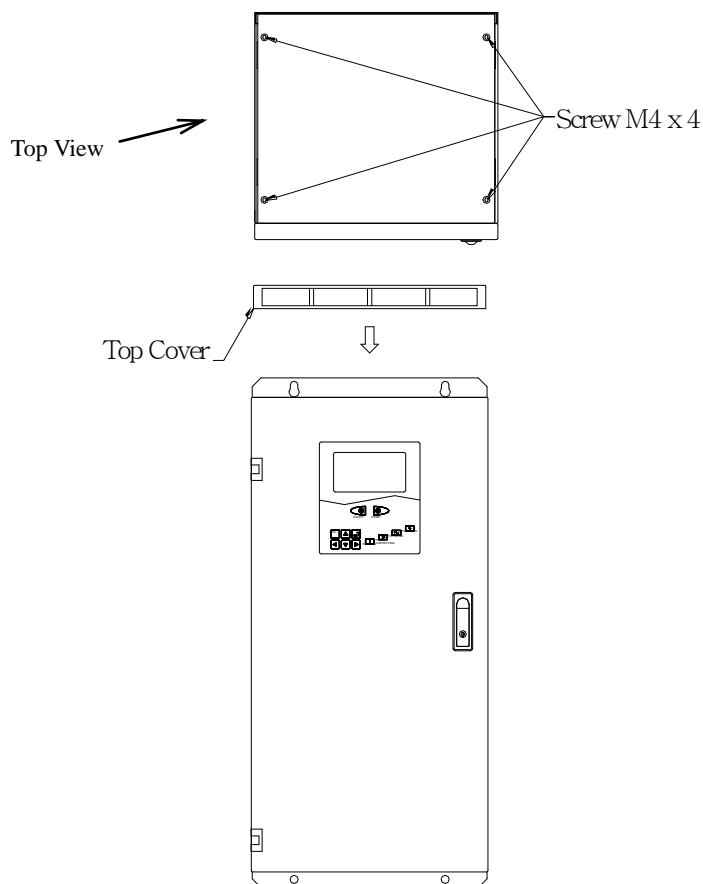

Drawing 2-1 Install Top Cover onto AHF-0025 & AHF-0050

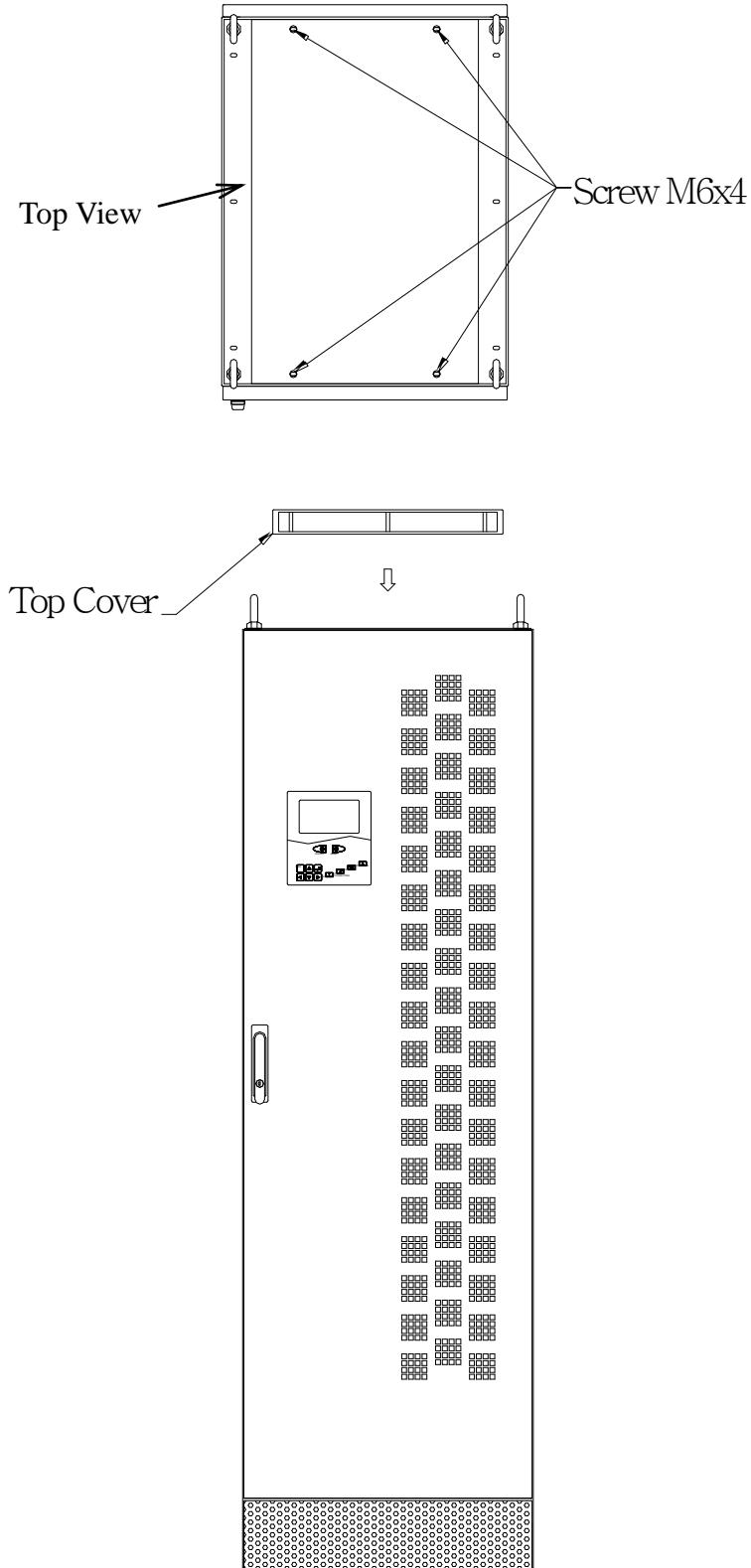

Drawing 2-2 Install Top Cover onto AHF-0100 & AHF-0150

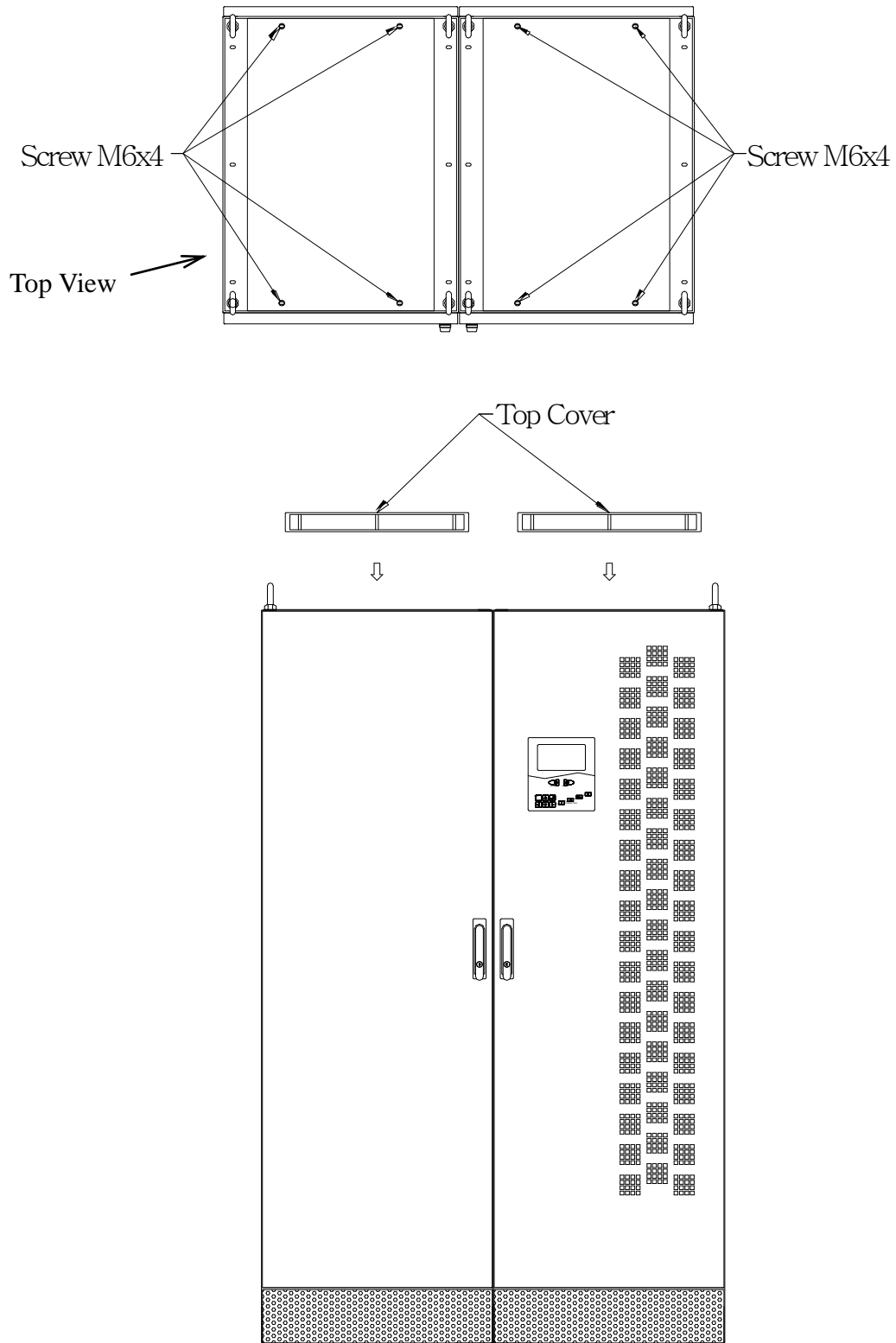

Drawing 2-3 Install Top Cover onto AHF-0200

GENERAL REQUIREMENTS FOR VENTILATION

Be sure to follow all national and local electrical codes and clearance requirements.

To allow proper air circulation and maintenance of the equipment, always allow minimum clearance as follows:

For Floor Standing AHF

- Four inches minimum between the rear of the AHF cabinet and the wall
- Minimum eight inches from the top of the AHF cabinet to the ceiling
- Minimum 32 inches from the front of the AHF cabinet to the wall or other equipment cabinet

For Wall Mounting AHF

- Minimum eight inches from the top of the AHF cabinet to the ceiling
- Minimum eight inches from the base of the AHF cabinet to the flooring
- Minimum 24 inches from the front of the AHF cabinet to the wall or other equipment cabinet

Floor Standing (100A, 150A & 200A)

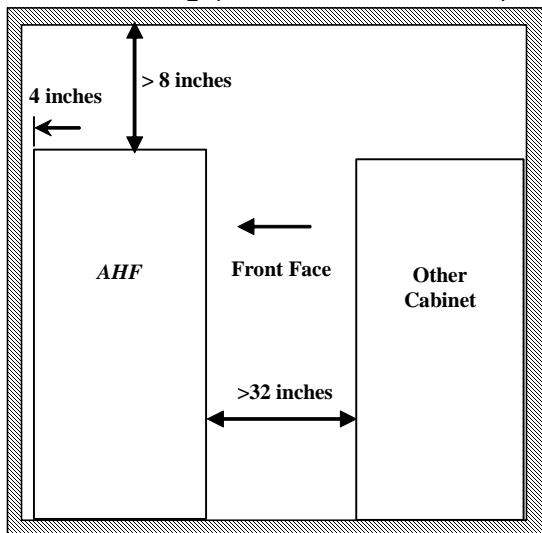

Wall Mounting (25A & 50A)

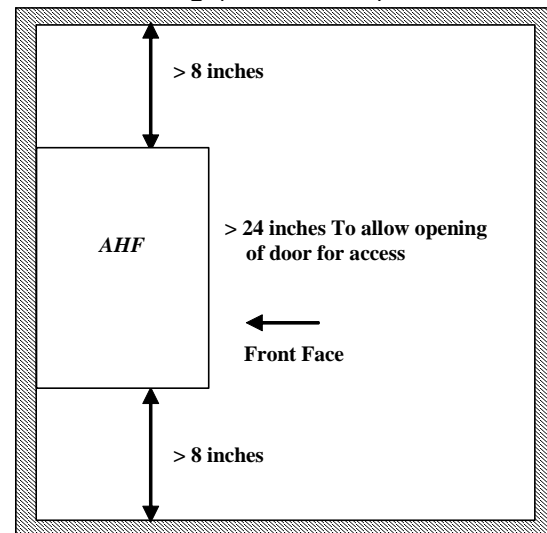

NOTE: ALWAYS ALLOW AT LEAST 6 INCHES FROM ANY COOLING FANS OR VENTILATION PORTS TO OTHER SURFACES (WALLS, OTHER ENCLOSURES, ETC).

WIRING CONNECTIONS

Cable requirements for the AHF are:

- Power cables, to be connected to power terminal block Q1.
- Grounding cable, to be connected to ground terminal (bar).
- CT output lines, to be connected to current signals terminal bar (TB1).

The recommended ideal wiring connections are as shown in drawing 2-4. All CTs are connected on Load side to detect load harmonic current for optimum filtering. Using this factory default connection, the changeover switch SW1-1 on Board APJ15 must be set to "Load" position.

Drawing 2-5 shows the connections of the CTs on Power Source side when the connections on Load side are not possible. This method of connection may not provide optimum filtering as compared to the connection shown in drawing 2-4. **Using this connection, the changeover switch SW1-1 on Board APJ15 must be set on "Source" position.**

 <p>CAUTION!</p>	To avoid possible interference with the CT output signal, do not place Power Cables and the CT twisted paired signal cable in the same tray or conduit. If both Power and Signal cables need to be in the same tray or conduit, ensure proper partitions are in place to provide isolation between them.
--	--

The appropriate ratings of power cables and over-current protection devices are required for use in conjunction with the AHF. These devices should adhere to local electrical regulations and the technical descriptions provided by the original equipment manufacturer. In addition, a minimum 10% over sizing to the Power Cables size and Over-Current Protection Devices is recommended, due to "skin effect" caused by the compensating harmonics generated by the AHF.

The ARTECHE AHF may not perform properly if power-factor correction capacitors are connected to the AC-bus down-stream from the current transformers (CT's). In addition to stand-alone connection, power factor capacitors may be enclosed in equipment. Refer to site on-line diagrams/equipment schematics to verify their absence.

For proper performance the following points must be observed:

- The phase sequence of the 3-phase power wires feeding the AHF must be positive sequence. i.e. a phase rotation meter should indicate "clockwise".
- DC-drives must have a 3-phase AC reactor (3% minimum) or a drive isolation transformer inserted between the ARTECHE AHF connection point and the drive AC input.
- Variable-frequency AC-drives must have a 3-phase AC reactor (3% minimum) or drive isolation transformer with electro-static shielding inserted between the connection point and the drive AC-input, unless the drive is a PWM type drive with a diode rectifier and has an internal DC-bus reactor. In that case AHF may be connected directly to the drive AC input terminals. Consult Artech for supply of reactors.

WIRING CONNECTION

Current Transformers (CT) installation: 2 required (included with AHF)

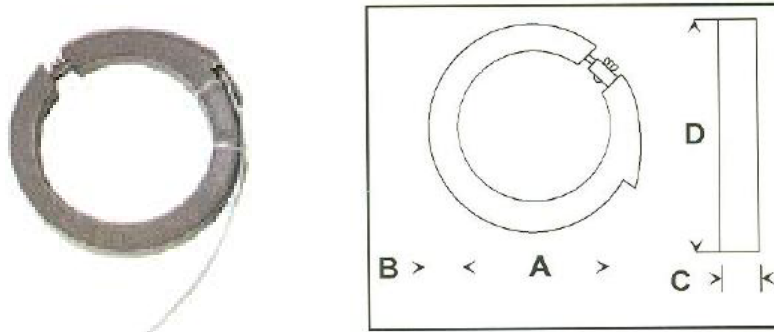

A	B	C
Inside diameter		Outside diameter
8.00 in	1.25 in	10.50 in

CT SPECIFICATIONS:

UL File No. E186575

Parameter	Specification	Parameter	Specification
Ratio	2000 : 1	Accuracy	1%
Voltage	600 Vac	Burden	18 VA
BIL	10kV (full wave)	Secondary Leads	12ft; spade connectors
Frequency	50 – 400 Hz	Weight	7 lbs (3.2kg)

INSTALLATION INSTRUCTIONS FOR CURRENT TRANSFORMERS

- Current transformers must be installed by a qualified electrician.

Do not attempt to connect current transformers (CT) or troubleshoot current transformers in the area where they are mounted while power is on as this may involve contact with dangerous voltages and power levels which could result in DEATH.

- **DO DISCONNECT** the main power before installing current transformers. If a main disconnect switch is not available on the power source side of the location where current transformers are to be connected, request your local electric utility company to turn off the facility power during installation.
- **MAKE SURE** the current transformers are mechanically mounted in a manner so that they will not shift (due to vibration, etc.) after installation. Center the CTs around the cable or bus in order to attain the greatest accuracy from the CT.
- **NEVER ALLOW** a current transformer to be energized while its secondary terminals are open-circuited as **dangerous voltages** may occur. Additionally, destruction of the CT could result.
- **DO NOT** attempt to connect CTs to any circuit with a voltage potential greater than 600VAC, 60Hz.
- **NO LIABILITY** will be assumed by Artech for mis-application of current transformers.

WIRING CONNECTION

CURRENT TRANSFORMERS (CT) INSTALLATION: (CONTINUED)

POLARITY INFORMATION

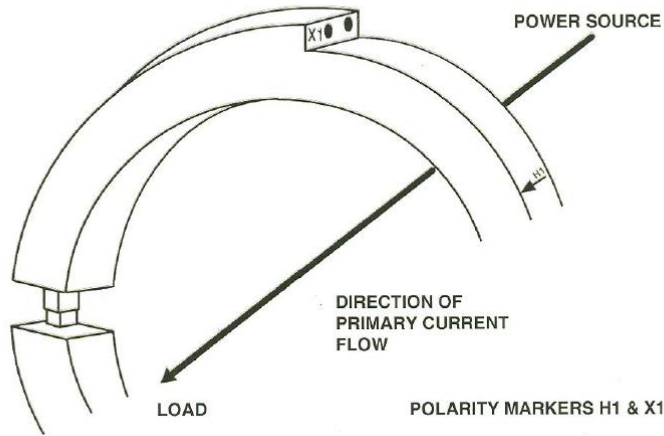

Note: Open split-core with a twisting motion only.

NOTE: Black Secondary lead is connected to X1.

MAXIMUM CT PRIMARY CURRENT

The CTs that are included with the AHF are intended for connection on a bus that is located electrically close to the load. The AHF must be selected based on a signal from the CTs that represents primary (bus) current within the limits included in this table.

FILTER Rating	MAXIMUM CT Primary Peak Current	MAXIMUM CT Primary RMS Current	MAXIMUM CT Secondary Peak Current
25	375 APK	265 ARMS	187MAPK
50	750 APK	530 ARMS	375MAPK
100	1500 APK	1060 ARMS	750MAPK
150	2250 APK	1590 ARMS	1.125APK
200	3000 APK	2120 ARMS	1.500APK

ALTERNATIVE CTs

Arteche includes the ideal CT with each AHF. If (due to bus bar geometry, etc) it is necessary to use a different style or size of CT, then the alternative CT should have the same ratio (2000:1).

NOTE: CONTACT THE FACTORY BEFORE USING ANY ALTERNATIVE CTs, AS DAMAGE TO THE AHF MAY OCCUR WHEN ALTERNATIVE CTs ARE USED.

WIRING CONNECTION - OPTIONAL CT LOCATIONS

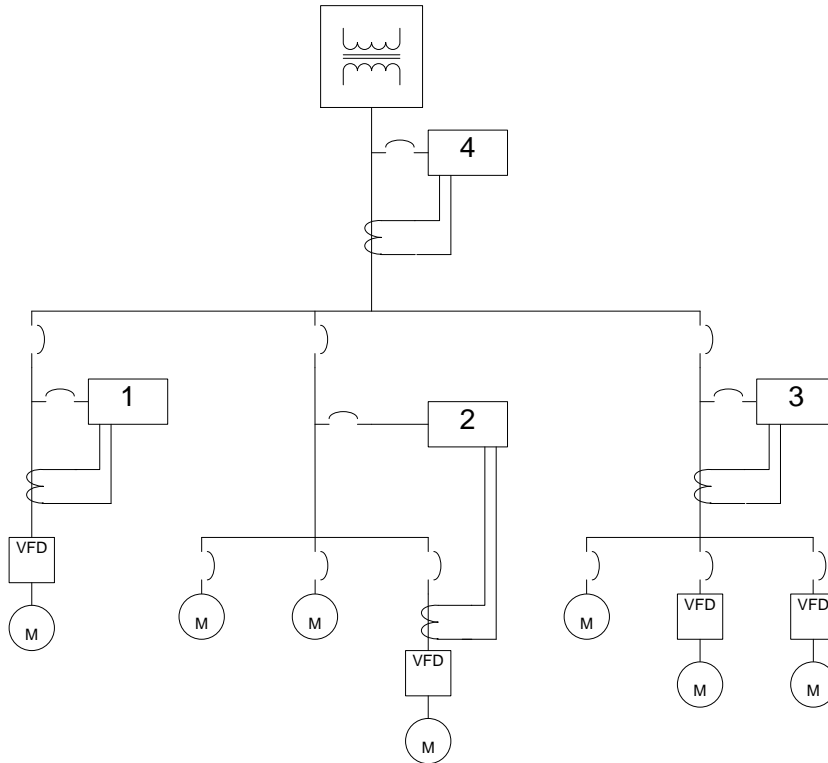

Type AHF active harmonic filters are intended to be connected on a bus that is close to the harmonic producing load(s). To check the suitability of a particular conductor for CT connection, measure the true RMS and peak currents in the conductor (prior to installing the CT) and check the maximum allowable RMS and peak current in the table on page 13, for the respective AHF rating. Both the RMS and peak currents must be within the maximum limits stated in this table. Consult factory for tie-bus arrangements and utility/generator bus arrangements for additional information.

CAUTION: Measure the current on the intended CT primary bus conductor prior to installing CT. Confirm that measured current is within the limits stated in the table on page 21.

Optional Locations for connection of AHF and CTs:

- 1) **This is the preferred connection method.** Confirm that bus current is within RMS and peak limits of AHF as per table on page 13.
- 2) This method of connection can be acceptable if the peak and RMS current in primary of CT is within the limits in the table on page 13. If CT primary current will be too high, change to method 1).
- 3) This method of CT connection is only possible if the AHF rating is high enough so that the CT primary current (RMS and peak) is lower than the limits for the respective AHF in the table on page 13. If CT primary current will be too high, change to method 1).
- 4) This connection method can rarely be used due to typical bus current ratings. Measure the RMS and peak current on the primary conduct Confirm that bus current is within RMS and peak limits of AHF as per table on page 13. If CT primary current will be too high, change to method 1).

WIRING CONNECTION (CTS)

NOTE: Upstream = power source direction; Downstream = Direction where all loads are connected to the system.

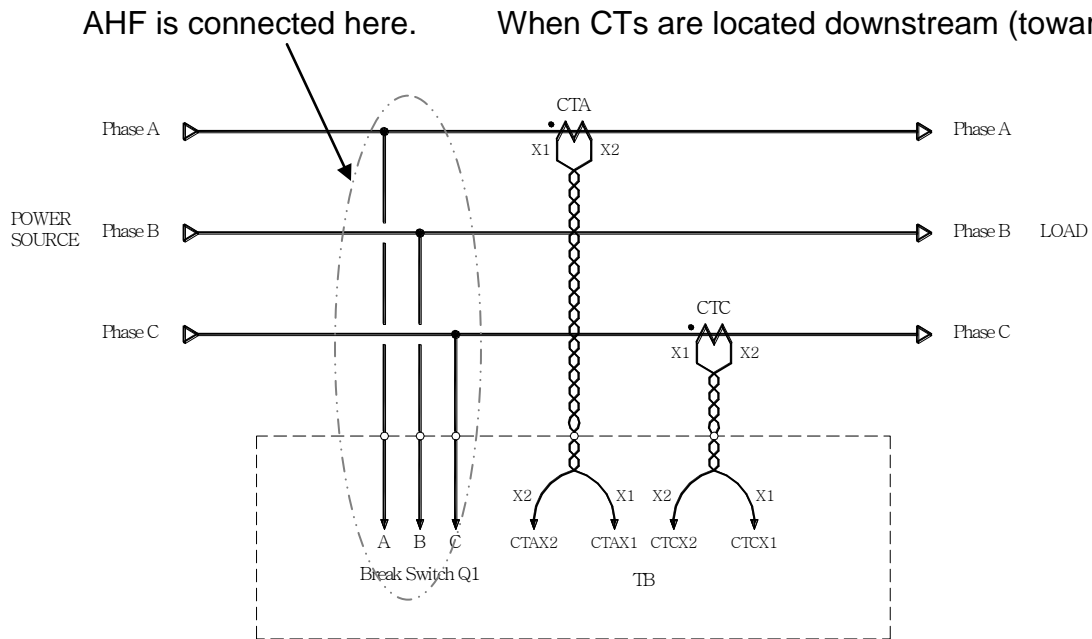

Drawing 2-4 Wiring Schematic Diagram for 2CTs at Load Side of the AHF

When CTs are located upstream (toward power source). AHF is connected here.

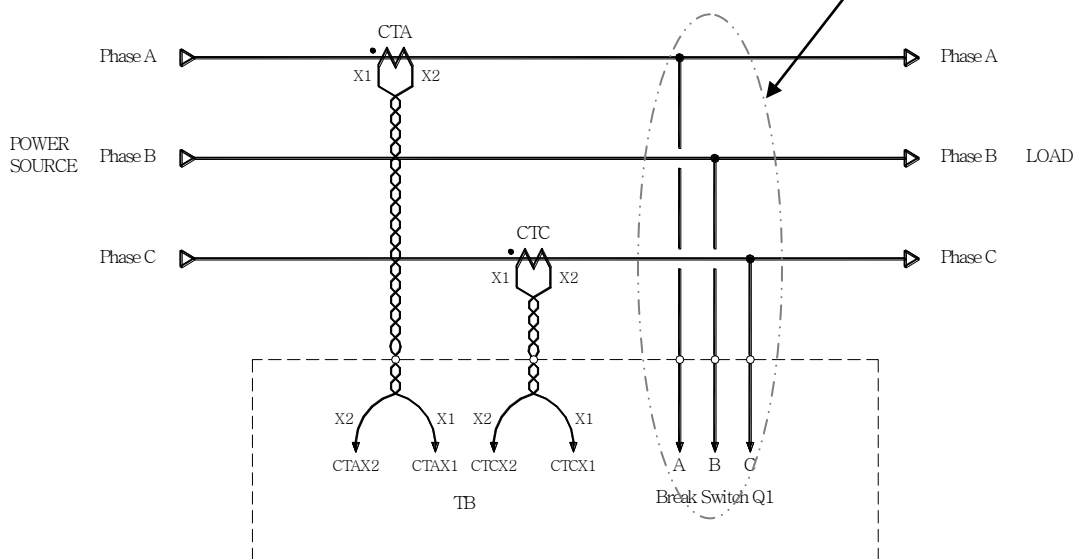

Drawing 2-5 Wiring Schematic Diagram for 2CTs at Source Side for the AHF

OPTIONAL CURRENT TRANSFORMERS

The standard current transformers used for Artech Type AHF active harmonic filters are rated for 2000 Amps maximum. In some cases, the rating of the bus conductor may be larger than this, requiring a special CT. In these cases, the active filter may be ordered with a special CT, although this requires a factory modification to the filter. Please contact factory in advance for a quotation.

MAX BUS AMPS	CT RATIO	STATUS
2000	2000:1	Standard
2500	2500:1	Special Order
3000	3000:1	Special Order
4000	4000:1	Special Order

NOTE: When ordering Type AHF active harmonic filters with CT for larger bus amps, be sure to specify the desired CT ratio.

Example:

For 100 Amp active harmonic filter with 2500:1 current transformer, order as Cat. No. AHF-0200-480-60-N1 with 2500:1 CT.

If using third party supplied CTs, Artech is not able to accept responsibility for the filter performance.

ADDITIONAL REFERENCE DRAWINGS

CT Placement with Capacitors

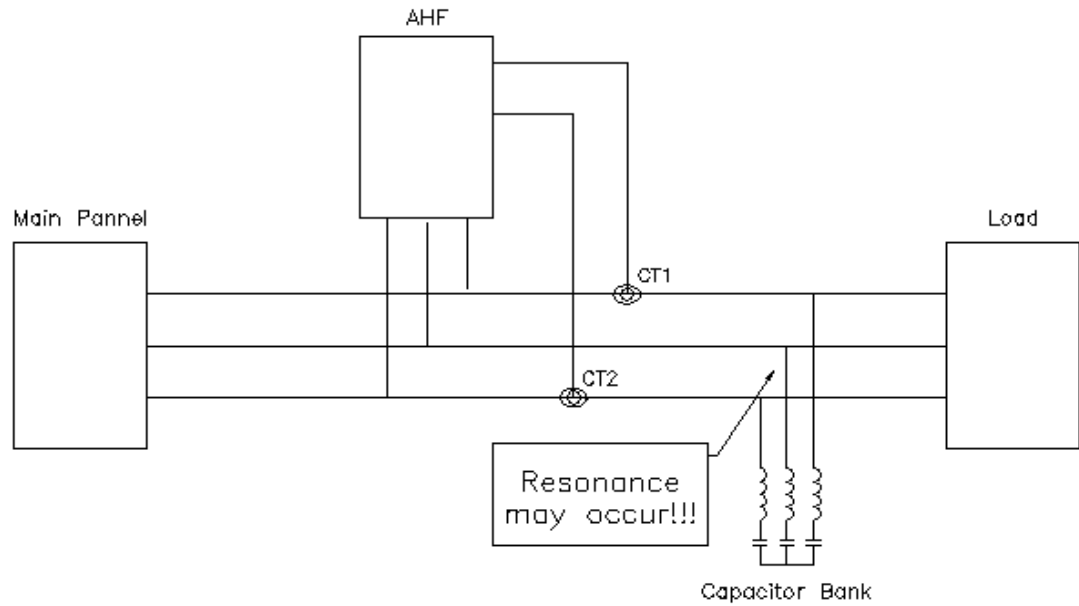

Unrecommended CTs Configuration with Capacitive Load

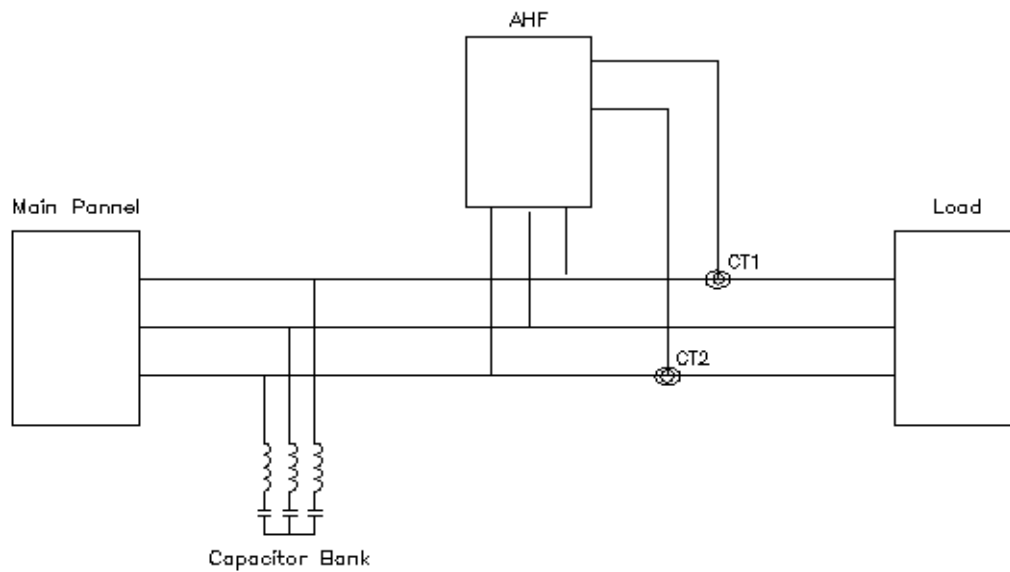

Recommended CTs Configuration with Capacitive Load

CT and Power Wiring Diagram for Paralleling Active Harmonic Filters

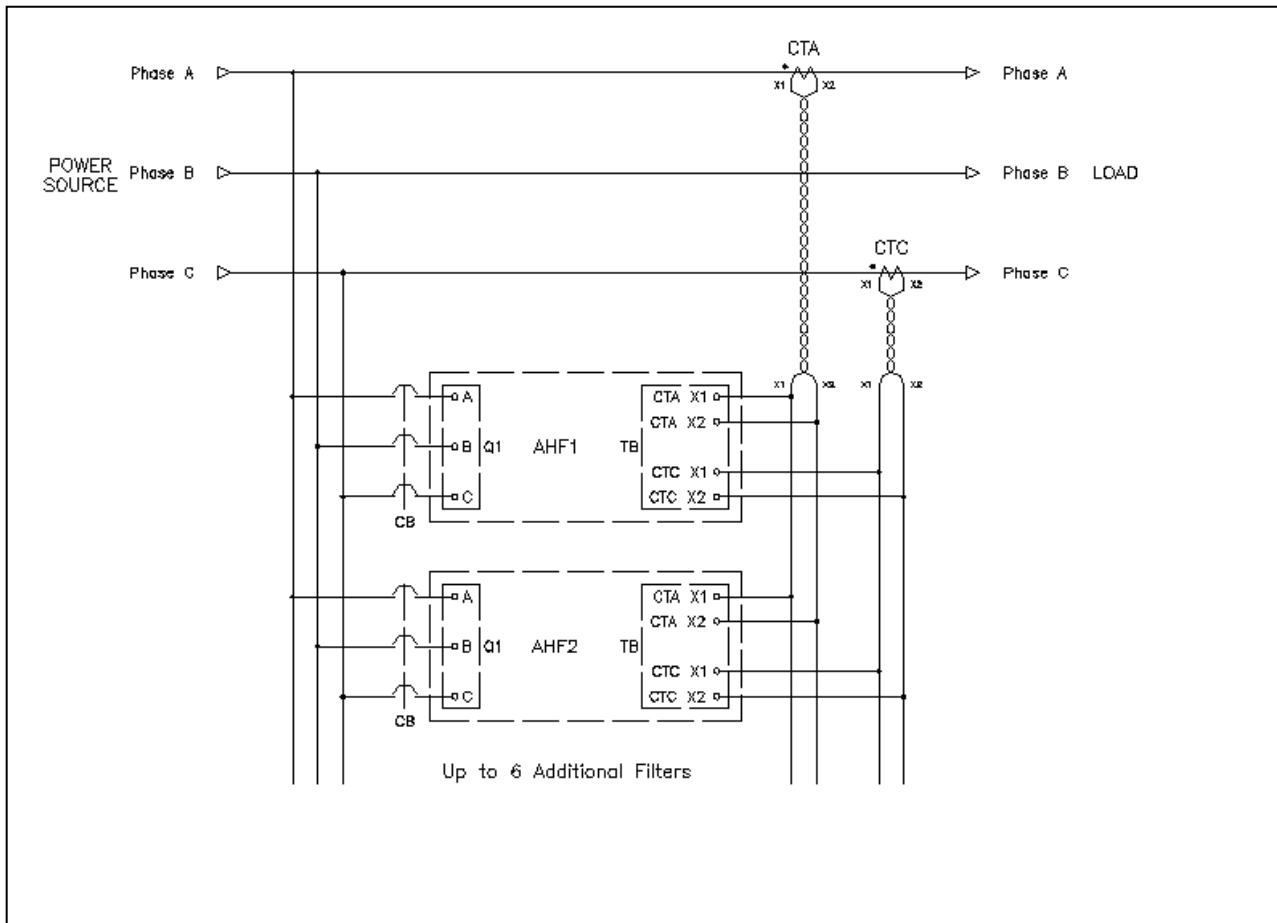

CT and Internal Wiring Diagram for Paralleling Active Harmonic Filters

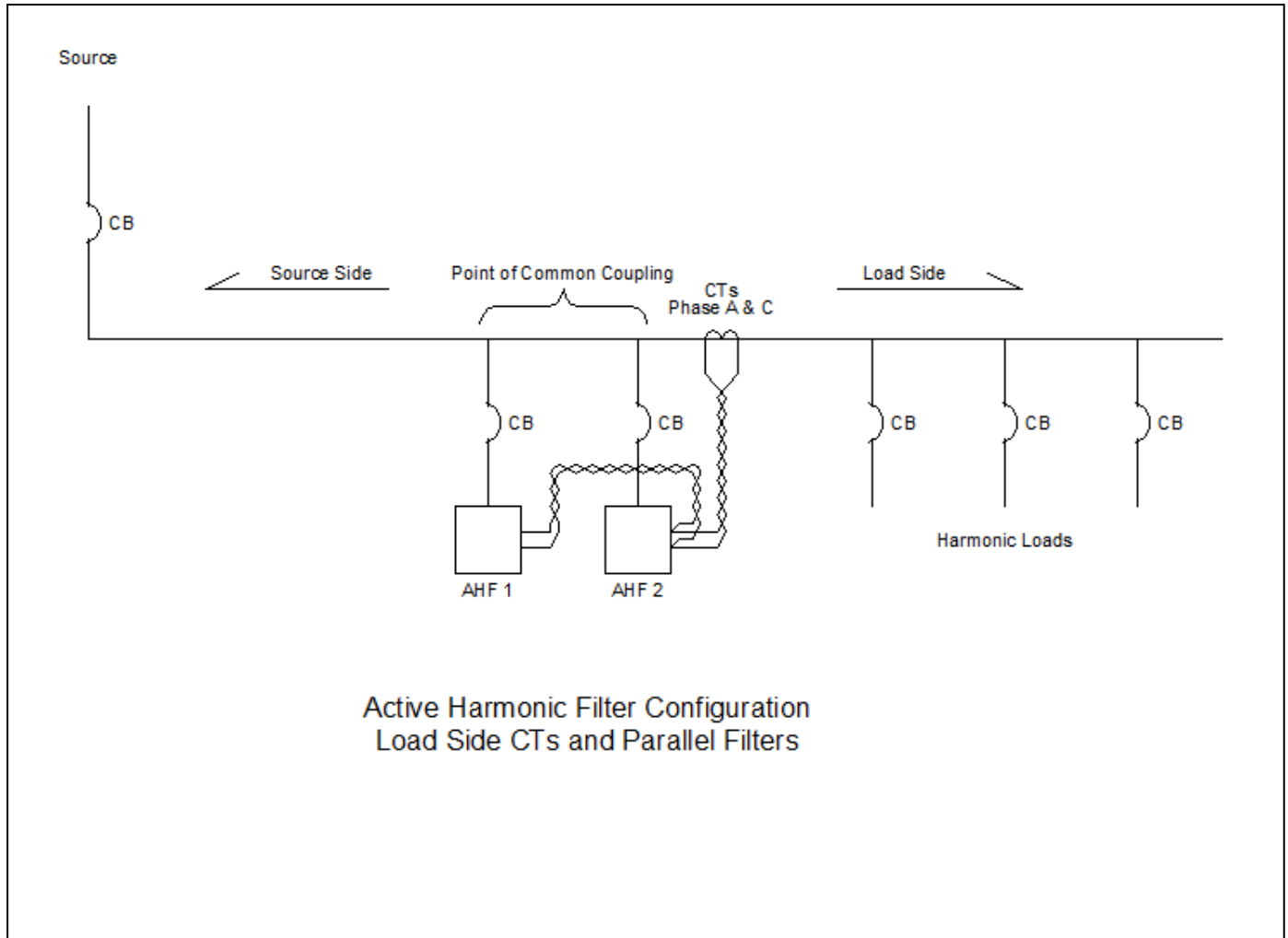

CONNECTION LAYOUT & SPECIFICATION

All cable entries are from the bottom of the AHF cabinet. The table below shows the type of terminals and their maximum allowable cable size capability.

Amp Rating	Connection to power terminal block Q1, allowable cable size	Ground connection type and cable size	Torque In. Lb.
25	Crimping type terminals, minimum 6AWG 75°C, maximum 4 AWG 75°C.	Grounding screw, (M6) minimum 8AWG 75°C.	26.5
50	Crimping type terminals, minimum 6AWG 75°C, maximum 4 AWG 75°C.	Grounding screw, (M6) minimum 8AWG 75°C.	26.5
100	Crimping type terminals, minimum 1/0 AWG 75°C, maximum 3/0 AWG 75°C.	Grounding copper bar, (M8) minimum 6AWG 75°C.	150
150	Crimping type terminals, minimum 1/0AWG 75°C, maximum 3/0 AWG 75°C.	Grounding copper bar, (M8) minimum 6AWG 75°C.	150
200	Crimping type terminals, minimum 2/0AWG 75°C, maximum 3/0 AWG 75°C.	Grounding copper bar, (M8) minimum 4 AWG 75°C.	150

NOTE – Important:

- 1) All high current filters utilize multiple units of lower current rated filters.
- 2) Wiring is to be made to individual filters.

Drawings 2-6 to 2-14 below show the physical dimensions and connection terminals layout of various AHFs.

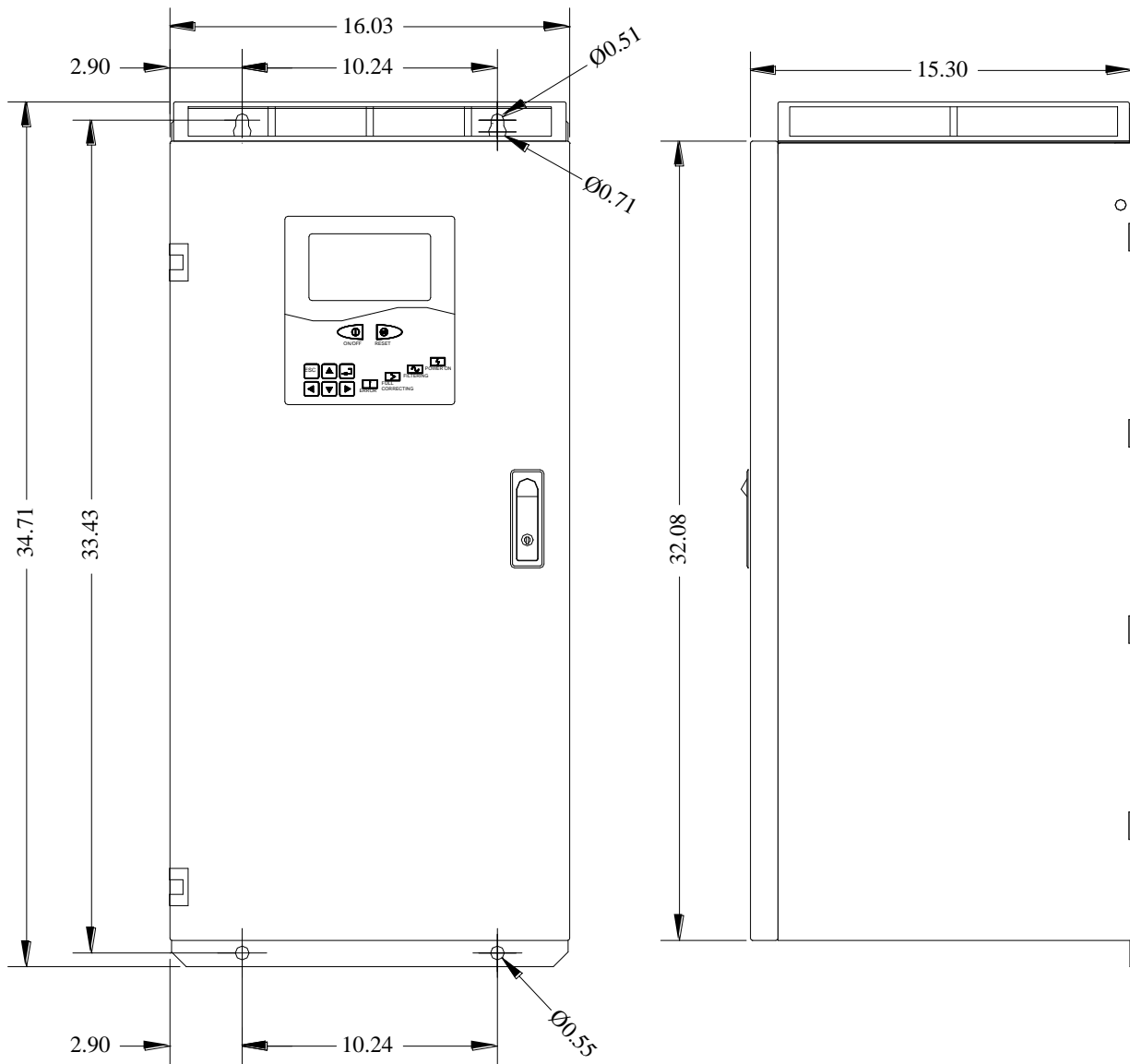

Drawing 2-6 AF-0025 & AF-0050 with LCD Control & Display Panel

Dimensions Diagram

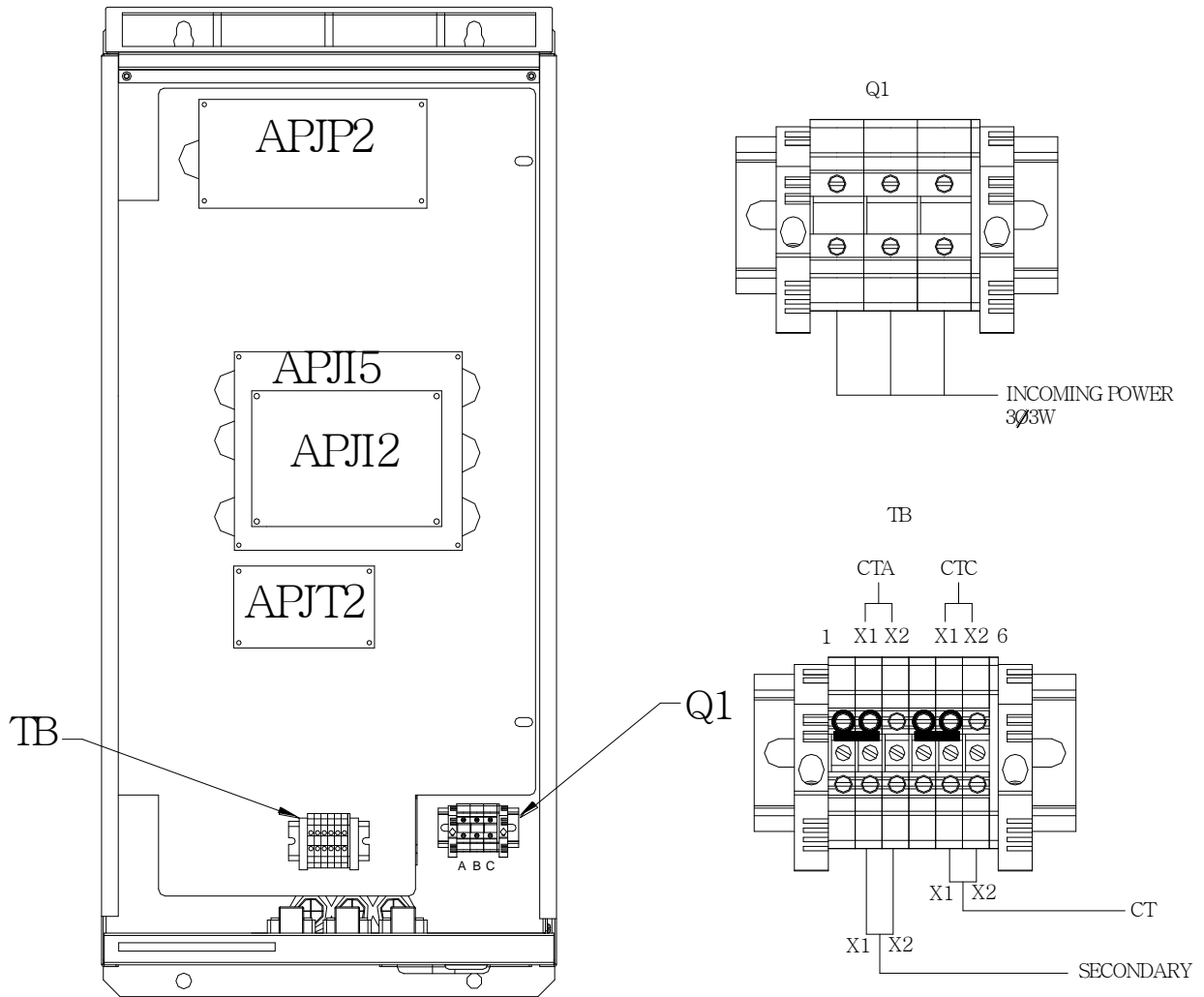

Drawing 2-7 AF-0025 & AF-0050 Wiring Position

Connections Diagram

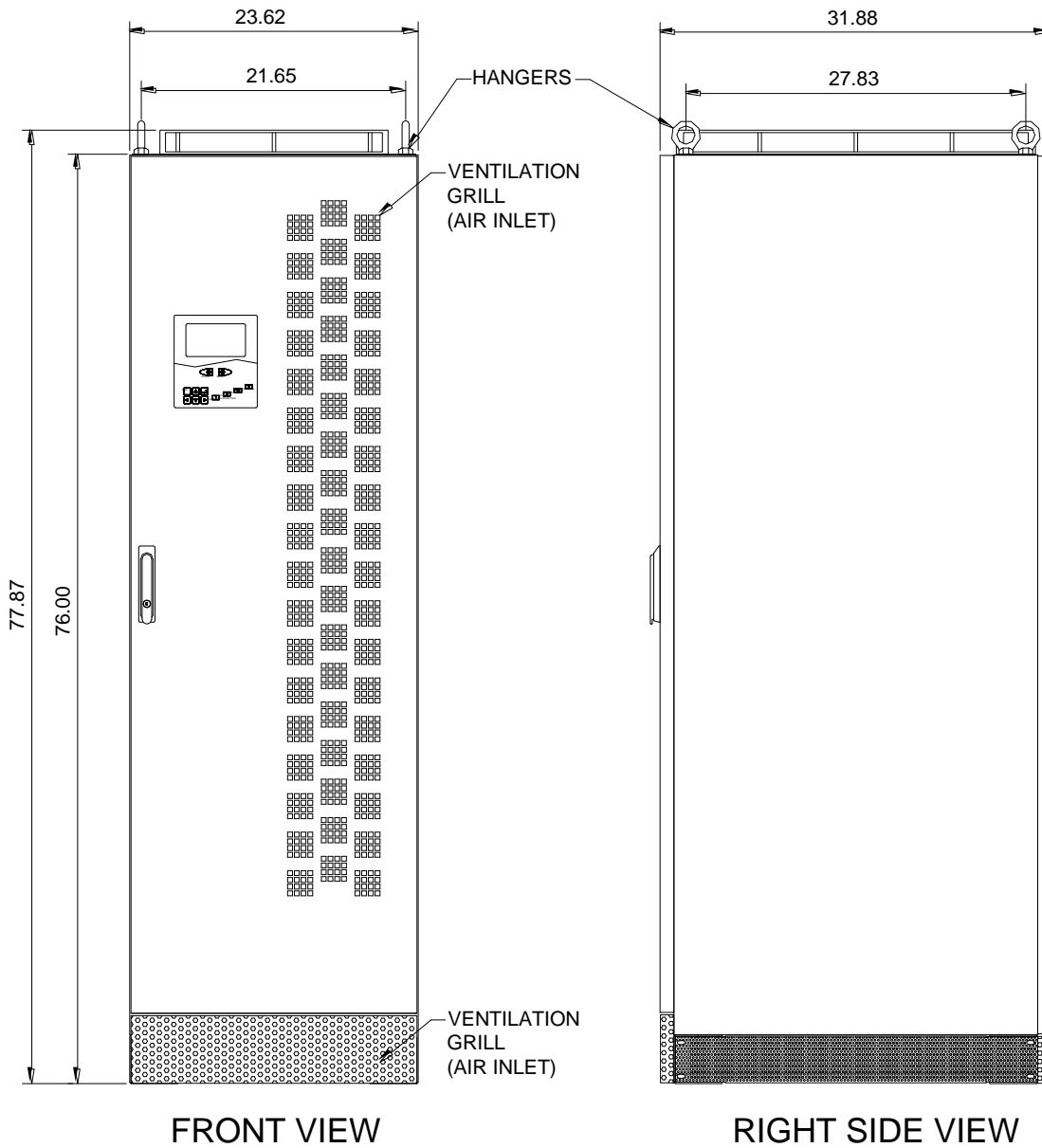

Drawing 2-8 AF-0100 & AF-0150 with LCD Control & Display Panel

Dimensions Diagram

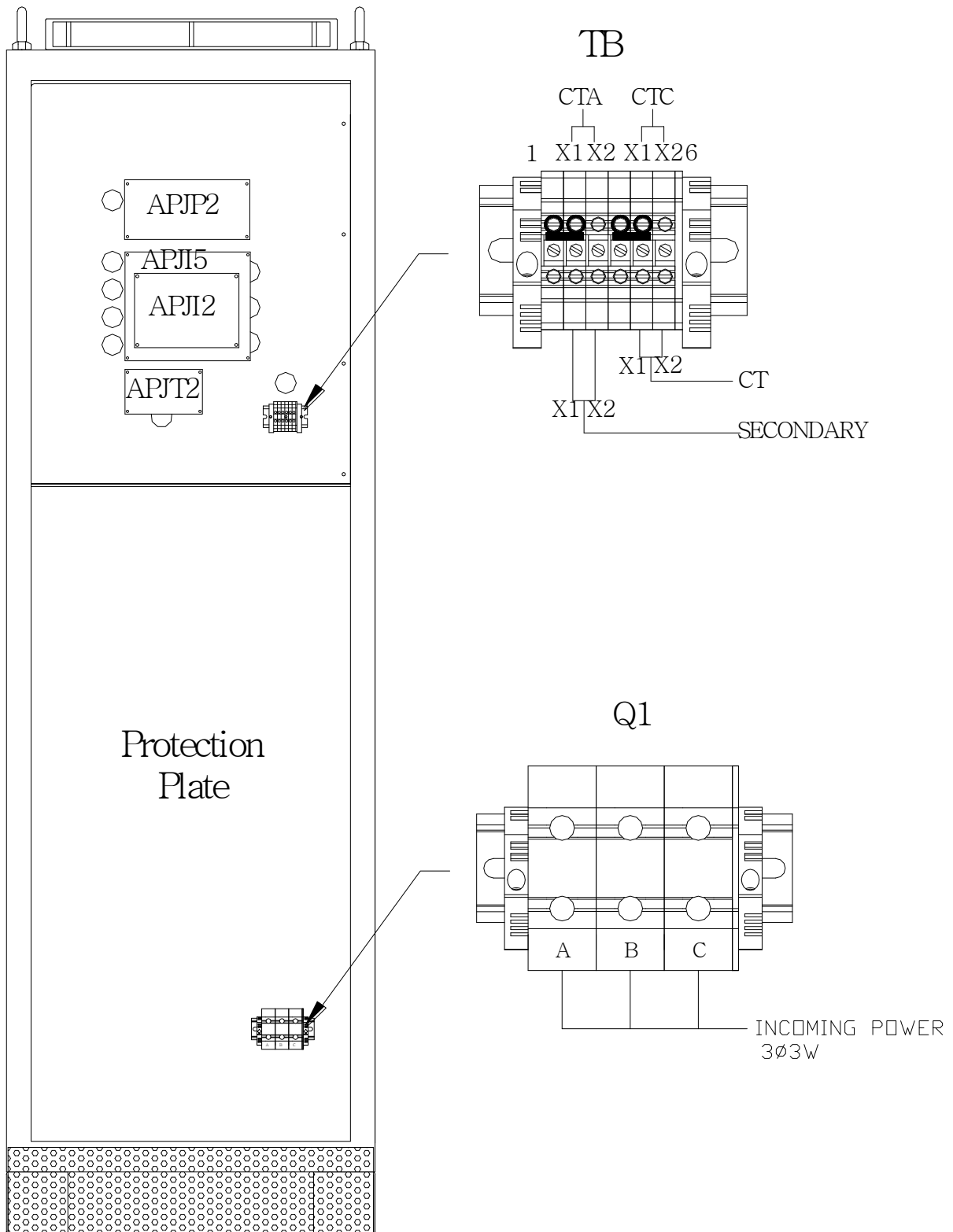

**Drawing 2-9 AF-0100 & AF-0150 Wiring Position
Connections Diagram**

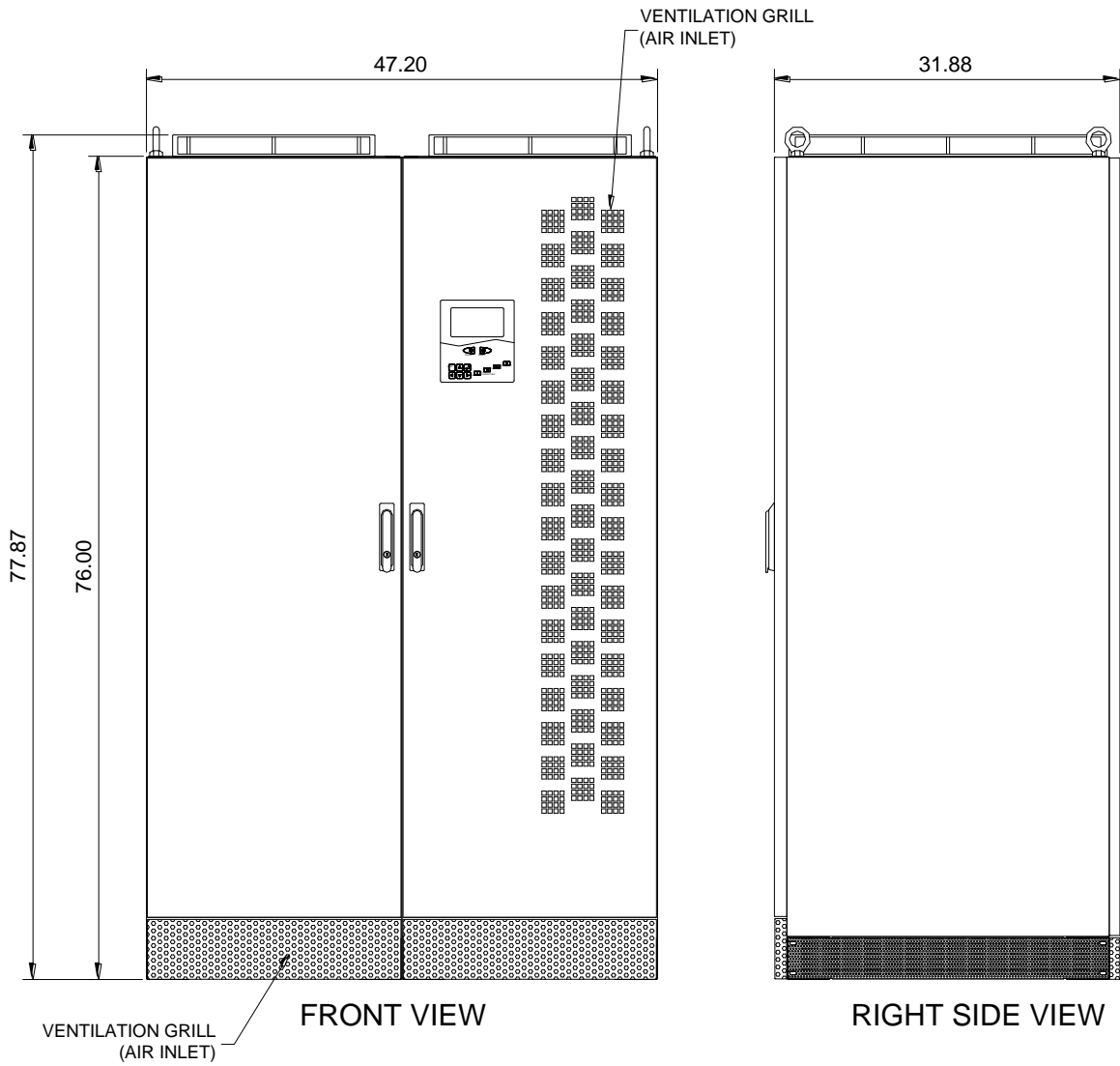

Drawing 2-10 AF-0200 with LCD Control & Display Panel

Dimensions Diagram

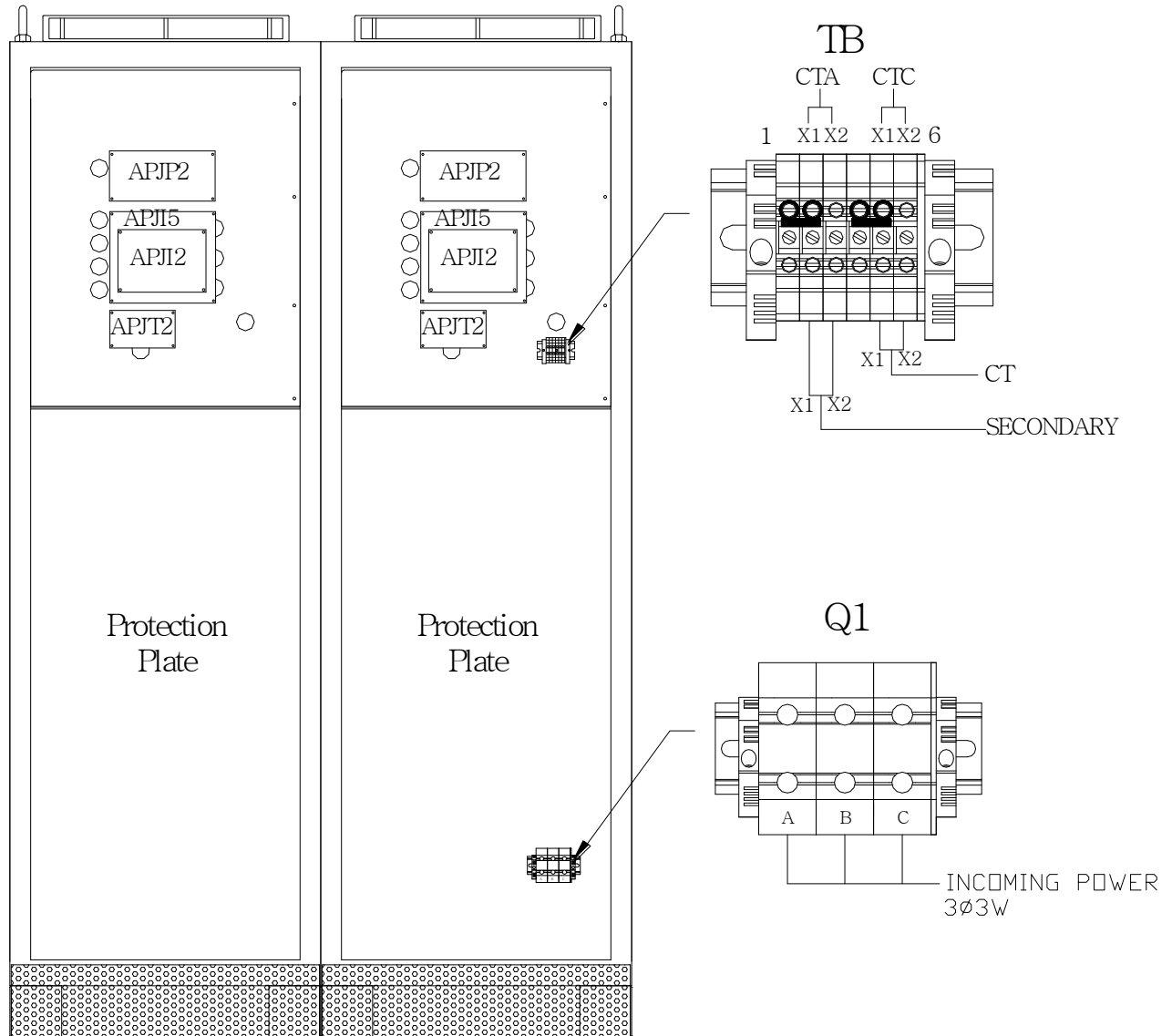

**Drawing 2-11 AF-0200 Wiring Position
Connections Diagram**

OPERATION

CONTROL PANEL

Summary

Each **ARTECHE** AHF is equipped with a control panel located on the front panel of the cabinet enclosure. The control panel allows a “Man-Machine” interface for operation control and provides the user with data, status, and alarm information. Control/Display is a back-lit LCD type with graphic capability and function keypads.

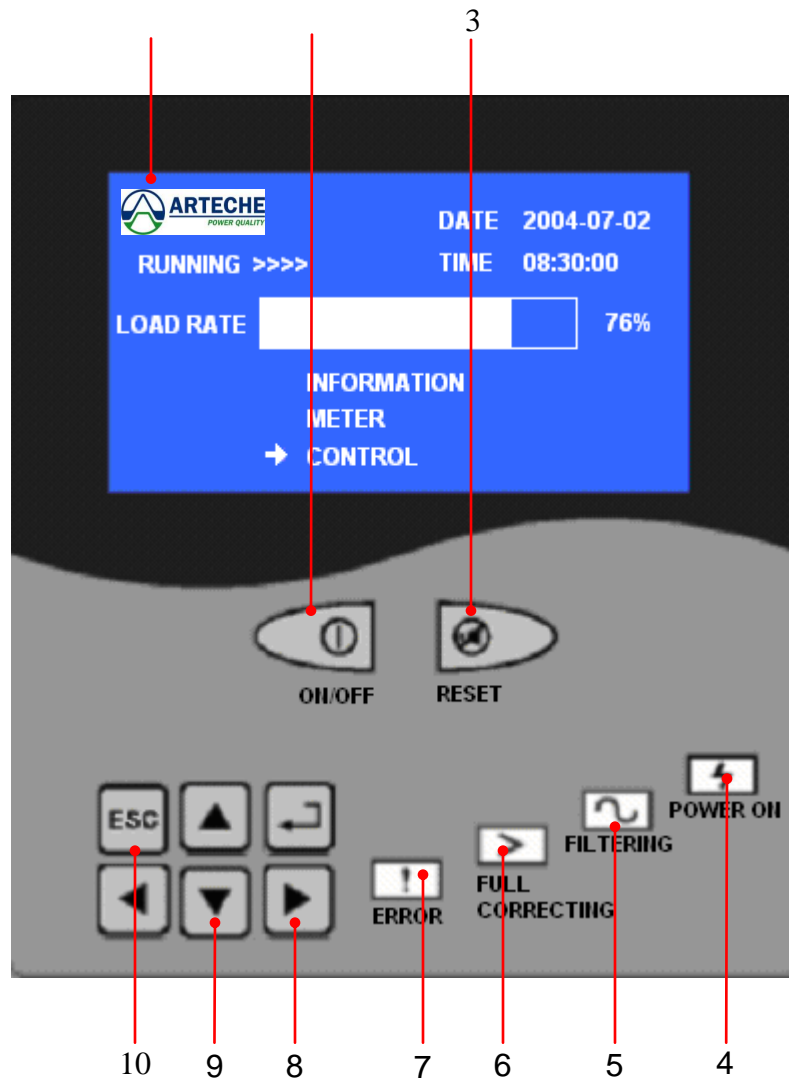

Drawing 3-1 Control Panel Diagram

- | | | | |
|----|------------------------------|-----|---------------------------|
| 1. | Display Screen | 6. | Full Correcting Indicator |
| 2. | On/Off Keypad | 7. | Error Indicator |
| 3. | Reset (Alarm Silence) Keypad | 8. | Confirmation/Enter Key |
| 4. | Power On Indicator | 9. | Directional Scrolling Key |
| 5. | Filtering Indicator | 10. | Escape/Cancel Key |

FUNCTIONAL DESCRIPTIONS

The control panel is made up of eight control keypads, four LED indicators, and one graphic LCD, which provide the following functions:

- Turning ON/OFF the AHF
- Clearing error status and silencing audible alarms
- Display all operating status

NOTE: Refer to LCD control and monitor panel User's Manual (Form No.M03-2031) for complete information on the AHF control panel.

CONTROL PANEL LED INDICATORS STATUS DESCRIPTIONS



POWER ON

Red LED indicator is **on**: indicates that the control logic circuits of the AHF are energized.



FILTERING

Green LED indicator is **on**: indicates that the AHF is providing the harmonic compensating current to the load. This indicator light will switch off when the AHF is shut down by the user or a system malfunction.



FULL CORRECTING

Yellow LED indicator is **on**: indicates that the load harmonic current is greater than the rated AHF compensating current. At this time, the AHF should be in current limit and continue to compensate the load harmonic up to its rated value.



ERROR

Red LED indicator is **on**: indicates that there are some possible external abnormal conditions or internal abnormal breakdown. The AHF has stopped providing any harmonic compensating current.

START-UP PROCEDURES

After completing all necessary electrical connections, please check:

- The AHF is correctly grounded
- Ensure all of the CTs are connected with the correct polarity
- The power system voltage is within the AHF 's tolerance

After the above conditions are checked, perform the following procedures:

1. Turn on utility power, allowing DC capacitor module to charge.
(*Note: After 30 seconds, the DC capacitor module should finish pre- charging*)
2. Perform the following checks before proceeding to step 3:
 - Ensure 'POWER ON' LED (red) indicator is *on*
 - Ensure that the cooling fans inside the AHF are operating
 - LD1, LD2, LD3, LD4, and LD5 on Board APJI2 inside the AHF should be *on*. LD1 to LD10 on Board APJI5 should be *off* when all connections are properly made and when the AHF is functioning normally.

(*Note 1: If APJI5 LD9 Light is On, CT A polarity is incorrect and should be reconnected; if the LD10 Light is On, CT C polarity is incorrect and should be reconnected.*)

(**Note 2:** *If APJI5 LD7 Light is On, the phase sequence is incorrect and should be reconnected.*)

(**Note 3:** *If filtering, full correcting, and error LED indicators on the control panel are flashing, and APJI5 LD8 light is on, the communication cable is disconnected between the control panel and APJI2. Please check that the communication cable is connected properly.*)

3. Press the control keypad 'ON/OFF', hold for two seconds, and confirm the following:
 - 'POWER ON' LED (red) indicator lights is on,
 - 'FILTERING' LED (green) indicator light is on. If this LED is flashing, the AHF accepted the turn-on command already and the DC capacitor module is still under soft-start charging.

(*Note: At this stage, an audible noise can be heard from the IGBT power converter module indicating it is in operation.*)

4. The AHF is now in full operation, providing harmonic compensation to the power system. To ensure the harmonic distortion is being reduced, perform the following:

- Measure and record the harmonic current on each phase at the load side.

Phase A _____ % THD-I **Phase B** _____ %THD-I **Phase C** _____ %THD-i

- Measure and record the harmonic current on each phase at the power source side.

Phase A _____ % THD-I **Phase B** _____ %THD-I **Phase C** _____ %THD-i

Calculate the **Harmonic Attenuation Ratio (HAR)**. The compensation ability of the AHF is defined in terms of HAR. Normally the AHR ratio is ≥ 10 .

Harmonic Attenuation Ratio

$$= \frac{\text{Harmonic current at load side (I}_{Lh})}{\text{Harmonic current at power source side (I}_{Sh})}$$

HAR (PHASE A) = _____ ÷ _____ = _____

HAR (PHASE B) = _____ ÷ _____ = _____

HAR (PHASE C) = _____ ÷ _____ = _____

SHUTDOWN PROCEDURES

 CAUTION!	Shutting down the AHF should only be carried out during repair or major maintenance of the entire power system or AHF to ensure minimum disruption to critical operations connected to the power system.
--	--

The following shutdown procedures should be performed only by authorized personnel:

1. Press the control keypad '**ON/OFF**' for one second, only '**POWER ON**' LED (red) indicator should remain on.
2. Turn off utility power to complete the shutdown procedures.

 DANGER	Before performing the actual repair to the AHF, wait at least for three minutes to ensure any residual current and voltage has been completely discharged from the DC Capacitors Module.
--	--

SILENCING THE ALARM

The AHF control panel provides both audible and visual alarms during abnormal system conditions or AHF malfunctions.

The alarm buzzer can be silenced by pressing the control keypad '**RESET**' for two seconds.

The '**ERROR**' indicator (red) LED remains on until the fault is cleared.

ON SITE TUNING PROCEDURES FOR OPTIMUM PERFORMANCE

The following inspections must be carefully checked prior to any tuning of the AHF:

1. The changeover switch SW1-1 on Board APJ15 must be set to the correct position according to the CTs location; refer to section – **“Wiring Connection”** of this manual. The factory default setting is for “LOAD”.
2. If other equipment also uses CTA and CTC, the changeover switch SW3 on board APJ15 must be set to the “OPEN” position. The factory default setting is for “CLOSE”.
3. Make sure that both the power cables and the CT twisted paired signal cables are not placed in the same tray or conduit.
4. Make sure that the CTs have been connected to the proper phases, CTA should be on phase A and CTC should be on phase C; please refer to section – **“Wiring Connection”** of this manual.
5. Make sure that the connections of CTs are not out of phase; please refer to section – **“Wiring Connection”** of this manual. (If the connection of CTA is out of phase, then the LD9 on board APJ15 will light up. If the connection of CTC is out of phase, then the LD10 on Board APJ15 will light up).

The following are on site tuning procedures for the AHF:

1. Turn on the harmonic load.
2. Perform the start-up procedures as per section – **“Start-Up Procedures”** of this manual.
3. Measure the THD-i of Phase A on the source side;
If the reading THD-i value is near to the targeted value, adjust VR1 on Board APJ15 until the THD-i reading is at the minimum value.
4. Measure the THD-i of Phase C on the source side;
If the reading THD-i value is near to the targeted value, adjust VR2 on Board APJ15 until the targeted THDI reading is achieved.
5. The THD-i reading of Phase B should be automatically reduced to its minimum value after the above procedures have been performed.

Note: The main function of VR1 and VR2 is to correct for the CTA and CTC tolerances. If the THD-i reading is quite different from the targeted value; please contact factory or authorized service agent.

POSITIONS OF LEDs AND SWITCHES ON PCB APJ15

Drawing 3-2 shows the positions of LED Indicators and Switches on PCB APJ15.

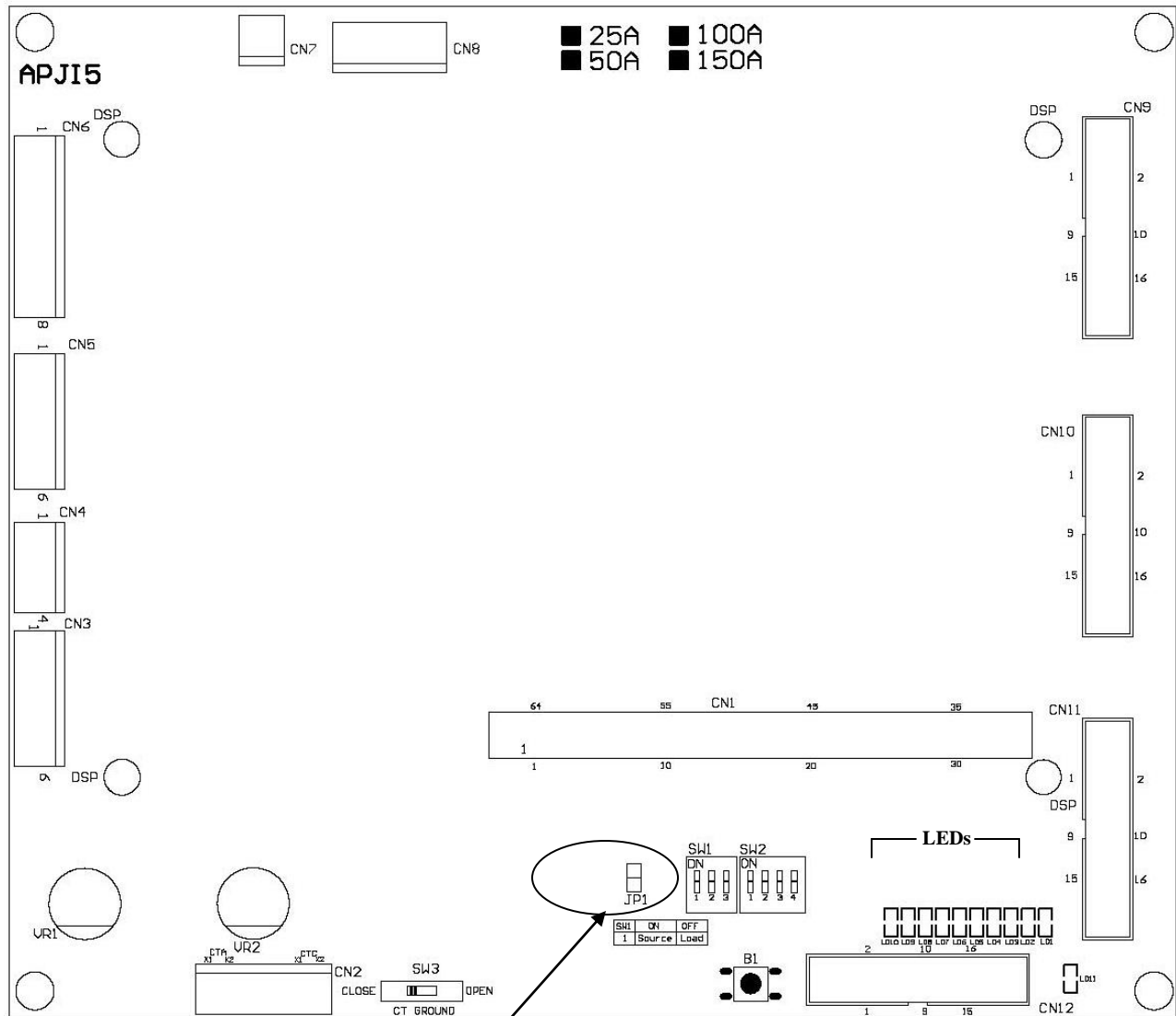

Drawing 3-2 The Positions of LEDs and Switches on PCB APJ15

NOTE: LOCATION OF JP1.

FUNCTION SETTINGS

This section describes the AHF setting functions, including the AHF current ratings, CT locations, harmonic compensation configurations, and smart save energy mode. The parameters setting and configuration are set with SW1 & SW2 on Board APJ15.

The AHF can effectively compensate harmonics, from the 3rd to 51st order. The compensated settings are divided into three categories as followings;

1. **Individual Selective Compensation:** The 3, 5, 7, 11, 13, 17, 19, 23, and 25 harmonics can be selected individually. A maximum of four orders can be enabled simultaneously.
2. **Higher-order Group Compensation:** Compensate simultaneously higher-order harmonics from the 15 to 51 components.
3. **Reactive Compensation Mode:** Disable harmonic compensation and only provide reactive power. The harmonic compensation mode setting descriptions are shown on the chart 3-3 of this manual.

SMART SAVE ENERGY MODE





The Smart Energy Saving mode provides the function of automatic start-up and shutdown, according to load current level. When load harmonic current is less than minimum-off current level, the AHF will shutdown automatically until the load harmonic current is greater than maximum-on current level. This feature is used to save energy by turning OFF filtering whenever the load harmonic current is less than 5% of the AHF unit rated current. It turns back ON when the load harmonic current increases to greater than 10% of the filter rated current (factory settings). In this mode, the AHF will also turn OFF the fixed KVAR provided by the filter, which also reduces the chances of having leading power factor. Refer below to chart 3-3 of this manual.

CONFIGURE HARMONIC SELECTION

The following are configuration procedures for harmonic selection compensation for the AHF:

1. Press the control keypad '**ON/OFF**' for one second to shutdown the AHF, only the '**POWER ON**' LED (red) indicator should remain on.
2. Use a short piece of jumper wire (not included) to connect both terminals of JP1 on board APJI5 together.
3. Press button S2 on board APJI2 for one second to reset the controller of the AHF.
4. Check the five LEDs from LD1 to LD5, on board APJI5. Each of these LEDs should be illuminated, indicating the AHF controller is ready for the configuration mode.
5. Remove the jumper wire from JP1 on board APJI5.
6. Determine the AHF current rating, and then refer to the chart 3-2 and set SW1 on board APJI5.

Chart 3-2 SW1 Setting

	Rated Current	25A 50A 100A 150A	200A
CT Location			
Load			
Source			

: ON : OFF

7. Refer to the chart 3-3 (next page of this manual), and then set SW2 on board APJI5 to select the desired harmonics compensation.
8. Press button B1 on Board APJI5 until the 5 LEDs, from LD5 to LD1, on Board APJI5 turn off sequentially. This indicates the new configuration parameters are effective.
9. Operate the control panel to turn on the AHF.

Chart 3-3 Harmonic Compensation Setting Description (SW2 Setting)

SW2 Setting				Setting Description
1	2	3	4	
X	ON	ON	ON	3, 5, 7, and 11 + higher-order harmonics
X	ON	ON	OFF	5,7,11, and 13 + higher-order harmonics(#1)
X	ON	OFF	ON	Compensate 3, 5, 7, and 11 harmonics
X	ON	OFF	OFF	Compensate 5, 7, 11, and 13 harmonics
X	OFF	ON	ON	Compensate 5, 7, and 11 harmonics
X	OFF	ON	OFF	Compensate 5 and 7 harmonics
X	OFF	OFF	ON	Only compensate 5 harmonic
X	OFF	OFF	OFF	Disable harmonic compensation and only provide reactive power.
ON	X	X	X	Smart save energy mode shall be enabled.
OFF	X	X	X	Smart save energy mode shall be disabled. (#2)

(#1): Factory default configuration of harmonic selection compensation.

(#2): Factory default of smart save mode.

Note: Specific harmonic orders from 3 to 13 can be selected individually by users. When selecting the individual harmonic orders from 17 to 25, please contact the factory or authorized service agent.

DRY CONTACTS

The AHF has five dry contacts (each rated 250V/2A) for remote monitoring purposes.

Chart 3-4 Dry Contacts Description

Item	Dry Contact	Description
1	POWER ON	The control logic circuit of the AHF is energized.
2	FILTERING	The AHF is providing the harmonic compensating current to the load.
3	FULL CORRECTING	The load harmonic current is greater than the rated AHF compensating current. At this time, the AHF should be in current limit mode and will continue to compensate the load harmonics up to its rated value.
4	ERROR	There are possible external abnormal conditions or an internal malfunction. The AHF has stopped providing any harmonic compensating current.
5	OVER TEMPERATURE	IGBT Module is above rated temperature.

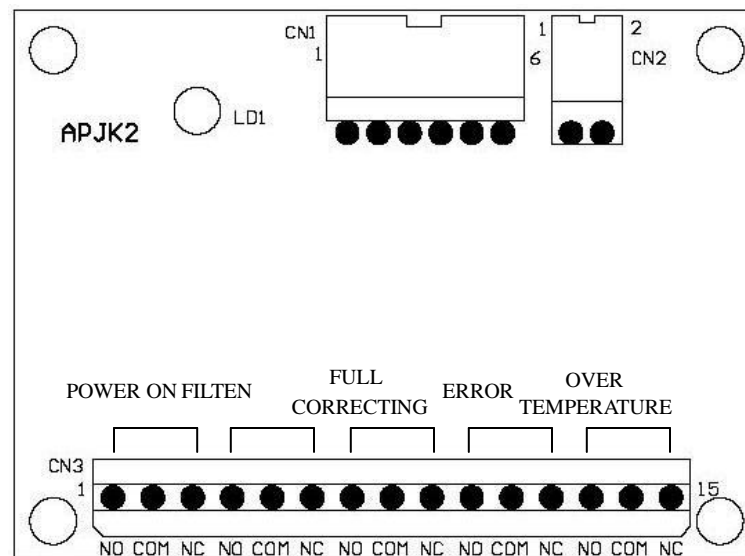

Drawing 3-3 The Positions of Dry Contacts on PCB APJK2

CLEARING THE ERROR STATUS & BASIC TROUBLESHOOTING

The AHF will shut down automatically when it encounters errors or faults. Some errors or faults are temporary and the AHF will resume normal operation when these errors/faults disappear. However, some errors/faults are critical and will cause the AHF to permanently shutdown. In order to resume normal operation, the error/fault status will need to be cleared after repairs are made.

To clear the error/fault status:

Press the control keypad 'RESET' for two seconds to silence the alarm.

The following chart shows the LED indicators on **board APJ15** inside the AHF with reference to the probable error/fault descriptions and the recommended corrective actions.

Chart 3-1 Board APJ15 LEDs Indicator Chart

LED #	Indicator Color	Error/Fault Descriptions	Corrective Action
LD1	Red	Pre-charge electromagnetic contactor module faulty. The contactor switch (MC1 or MC2) tripped or malfunctioned. The AHF shuts down automatically.	Clear the error status using the procedure stated above. Restart the AHF. If the problem persists contact factory or authorized service agent.
LD2	Red	IGBT module over temperature. The AHF shuts down automatically.	Cooling fans may be faulty. Clear the error status by following the procedure stated above. Restart the AHF. Listen for the mechanical sound when the fans start up. If the fans fail to start up or produce abnormal mechanical noise, shut down the AHF. Contact factory or authorized service agent.
LD3	Red	Over current relay (OL1) tripped. Ripple current filter module is overloaded. The AHF shuts down automatically.	This may be caused by a source voltage distortion, resonance with capacitors in the system or an AHF IGBT fault. Clear the error status using the procedure stated above. Restart the AHF. If the problem persists, contact factory or authorized service agent.
LD4	Red	System voltage is abnormal. The AHF shuts down automatically.	The AHF will turn on automatically when normal system voltage has resumed.
LD5	Red	The output current of IGBT power converter module has high frequency resonance. The AHF shuts down automatically.	The loads may be over capacitive. Clear off the error status by following the procedure stated above. Restart the AHF. If the problem persists, contact factory or authorized service agent.

LED #	Indicator Color	Error/Fault Descriptions	Corrective Action
LD6	Red	DC bus over-voltage. The AHF shuts down automatically.	The AHF will turn on automatically when the DC bus voltage is under 380V.
LD7	Red	Phase sequence incorrect or frequency over specification. The AHF will not start-up operation or it shuts down automatically.	Ensure the power cable is connected with the correct phase sequence, if not the power cable should be reconnected. The AHF will turn on automatically when frequency is normal.
LD8	Red	Communication is disconnected between control panel and PCB APJ12.	The control panel is not functioning. Check that the communication cable is connected properly.
LD9	Red	Filtering off, the current Transformer A (CT A) polarity is incorrect.	CT A should be reconnected.
		When filtering is on and phase A harmonic load current is greater than the AHF rated capacity. The full correction LED indicator on the control panel will also light up, indicating that the AHF is in current limit condition.	The AHF capacity is under rated to compensate for all of the harmonics present. Use a harmonic analyzer to confirm the real value of the harmonics. Upgrade the AHF capacity or install additional units in parallel with the existing the AHF.
LD10	Red	Filtering off, the current transformer C (CT C) polarity is incorrect.	CT C should be reconnected.
		When Filtering On and Phase C harmonic load current is greater than AHF rated capacity. The full correction LED indicator on the control panel will also lights up, indicating that the AHF is in current limit condition.	Same as Above
LD11	Red	CN12 on APJ15 is connected correctly.	Note: CN12 is only used in AHF-0200.

TROUBLESHOOTING (Service Manual is also available for qualified personnel).

LED (Board AJP15) Indicator Function Explanation

LED No.	Color	Description
LD1	RED	Soft-start Electromagnetic Contactor Module faulty. The contactor switch (MC1 or MC2) is tripped or malfunction. <i>AHF</i> shutdown automatically and the ERROR LED indicator on the Control Panel will also lights up.
LD2	RED	IGBT Module over temperature. <i>AHF</i> shutdown automatically and the ERROR LED indicator on the Control Panel will also lights up.
LD3	RED	Over Current Relay (OL1) tripped. Ripple current filter module is overloaded. <i>AHF</i> shutdown automatically and the ERROR LED indicator on the Control Panel will also lights up.
LD4	RED	Abnormal control power supply or AC main voltage. <i>AHF</i> will not start up from operation or shutdown automatically.
LD5	RED	The output current of IGBT Power Converter Module happen High Frequency Resonance. <i>AHF</i> shutdown automatically and the ERROR LED indicator on the Control Panel will also lights up.
LD6	RED	DC bus over-voltage. <i>AHF</i> shutdown automatically.
LD7	RED	Phase sequence incorrect or frequency over specification. <i>AHF</i> will not start up or shutdown automatically.
LD8	RED	Communication is disconnected between Control Panel and PCB APJ12.
LD9	RED	When Filtering Off, CT A polarity is incorrect and the ERROR LED indicator on the Control Panel will also light up. <i>AHF</i> will not start up.
		When Filtering On and Phase A harmonic load current is greater than <i>AHF</i> rated capacity. The Full Correction LED indicator on the Control Panel will also lights up, indicating that <i>AHF</i> is in current limit condition.
LD10	RED	When Filtering Off, CT C polarity is incorrect and the ERROR LED indicator on the Control Panel will also light up. <i>AHF</i> will not start up.
		When Filtering On and Phase C harmonic load current greater than <i>AHF</i> rated capacity. The Full Correction LED indicator on the Control Panel will also lights up, indicating that <i>AHF</i> is in current limit condition.
LD11	RED	CN12 on APJ15 is connected correctly. This LED only lights up on 200A unit of <i>AHF</i> .

BASIC INSTALLATION AND MAINTENANCE

Correct installation is required for proper performance and function of the active filter. Physical inspection of equipment for damage is recommended, prior to any installation.

Indoor storage is recommended for indoor rated equipment and should be in a clean, dry environment. Outdoor storage of outdoor rated equipment may require installation of additional materials shipped for site assembly. Where recommended, packaging materials may be required to be removed.

Equipment includes lifting lugs, for transport and site installation handling. As a cautionary note, placement of the AHF is to be at a level and solid location, for correct operation.

National Electrical Code (NEC), is to be observed during the installation. Electrical connections are also to be in compliance with required codes

It is recommended that the installer inspect and verify proper alignment, anchorage and grounding, proper connections and tightness of connections, prior to any start-up functions.

- Generally, AHF's are considered to be maintenance free devices. The following Inspections should be made during regular maintenance intervals:
- Remove any excess dust or dirt that may have accumulated within cabinet.
- Perform visual exterior and interior inspection
- Note any lights/alarms and take corrective action
- Check display to assure AHF is providing correct harmonic cancellation

Technical support is available by contacting the factory:

Telephone **1-262-754-3883**

Fax **1-262-754-3993**

Email info@artechepq.com

Website www.artechepq.com



ARTECHE PQ, INC.

16964 West Victor Road
New Berlin, WI 53151